

智能型 BA 系列电流传感器

Intelligent BA series current sensor

安装使用说明书 V1.5

Installation and Operation Instruction V1.5

申 明

DECLARATION

版权所有，未经本公司之书面许可，此手册中任何段落，章节内容均不得被摘抄、拷贝或以任何形式复制、传播，否则一切后果由违者自负。

本公司保留一切法律权利。

No part of this publication may be reproduced, stored in a retrieval system, or transmitted in any form by any means, electronic, mechanical photocopying, recording, or otherwise without prior permission of Acrel. All rights reserved.

本公司保留对本手册所描述之产品规格进行修改的权利，恕不另行通知。

订货前，请垂询当地代理商以获悉本产品的最新规格。

This company reserve power of revision of product specification described in this manual, without notice.
Before ordering, please consult local agent for the latest specification of product.

目录

CONTENTS

1 概述 Overview.....	1
2 产品型号 Product model.....	1
3 产品规格 Product specifications.....	2
4 外形及安装 Shape and installation.....	3
4.1 一体式 One-piece shape.....	3
4.2 分体式 Split-type shape.....	3
4.3 端子及接线 Terminals and wiring.....	4
4.3.1 电源和模拟量输出 Power supply and analog output.....	4
4.3.2 485 通讯和网口 485 communication and network port.....	5
5 通讯协议 Communication protocol.....	5
5.1 协议简述 Brief description of the protocol.....	5
5.2 传输方式 Transmission method.....	6
5.2.1 数据帧格式 Data frame format.....	6
5.2.2 地址域 Address field.....	6
5.2.3 功能域 Functional field.....	6
5.2.4 数据域 Data field.....	6
5.2.5 错误校验域 Error Check Field.....	7
5.2.6 错误检测的方法 Methods of error detection.....	7
5.3 功能码简介 Introduction to function codes.....	8
5.3.1 功能码 03H: 读寄存器 Function code 03H: read register.....	8
5.3.2 功能码 10H: 写寄存器 Function code 10H: write register.....	9
5.4 通讯地址表 Communication address table.....	10
5.5 电流信号解析 Current signal analysis.....	11
6 订货范例 Order example.....	11

1 概述

智能型 BA 系列电流传感器应用电磁感应原理，对电网中的交流电流进行实时测量，采用恒流和线性补偿技术，将其隔离变换为标准的直流信号输出，或通过 RS485 接口（Modbus-RTU 协议）将测量数据进行传输。DC24V 或 12V 安全电压供电，可广泛用于工业自动化领域。BA50L(II)-AI 为交流剩余电流互感器，主要检测用电系统的漏电流，能随时掌握电气线路和设备的情况，防止因漏电而发生的火灾等事故。

外形分为一体式和分体式，如图 1 和图 2 所示。

1 Overview

The intelligent BA series current sensor uses the principle of electromagnetic induction to measure the AC current in the power grid in real time and uses constant current and linear compensation technology to isolate and transform it into a standard DC signal output, or through the RS485 interface (Modbus-RTU protocol) to transmit the measurement data. DC24V or 12V safety voltage power supply, can be widely used in the field of industrial automation. BA50L(II)-AI is an AC residual current transformer, which mainly detects the leakage current of the electrical system, can grasp the status of electrical circuits and equipment at any time, and prevent fires and other accidents caused by leakage.

The shape has one-piece and split-type, as shown in Figure 1 and Figure 2.



图 1 一体式外形
Figure 1 One-piece shape



图 2 分体式外形
Figure 2 Split-type shape

2 产品型号

2 Product model



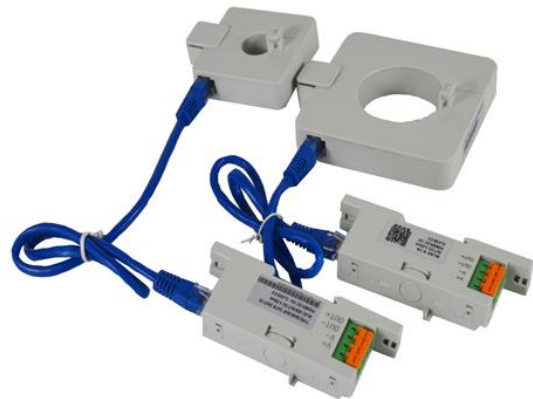
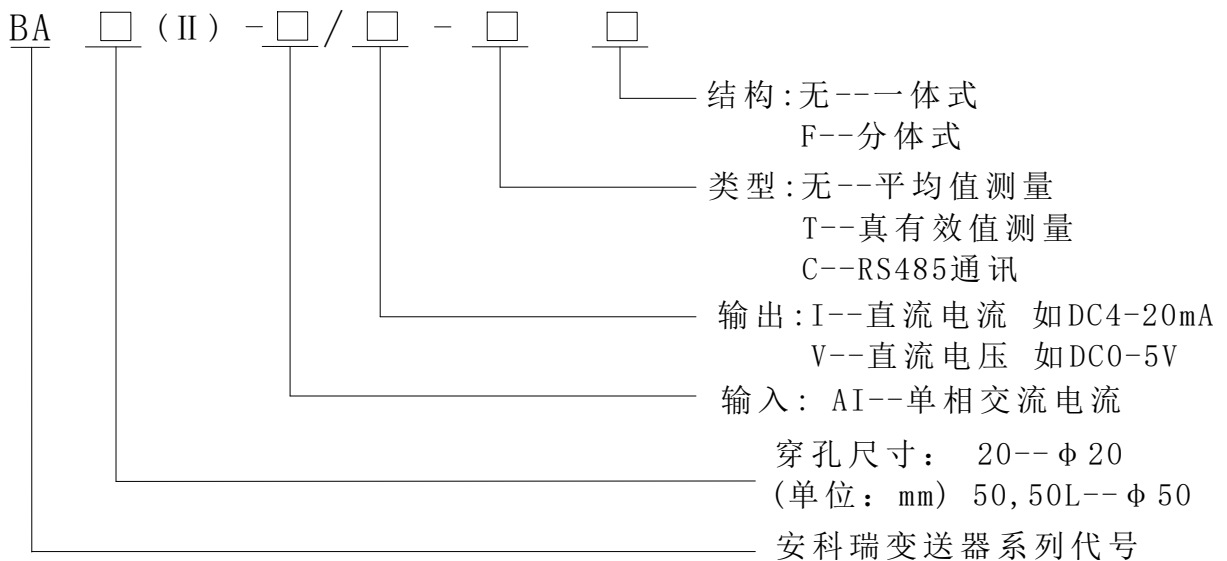
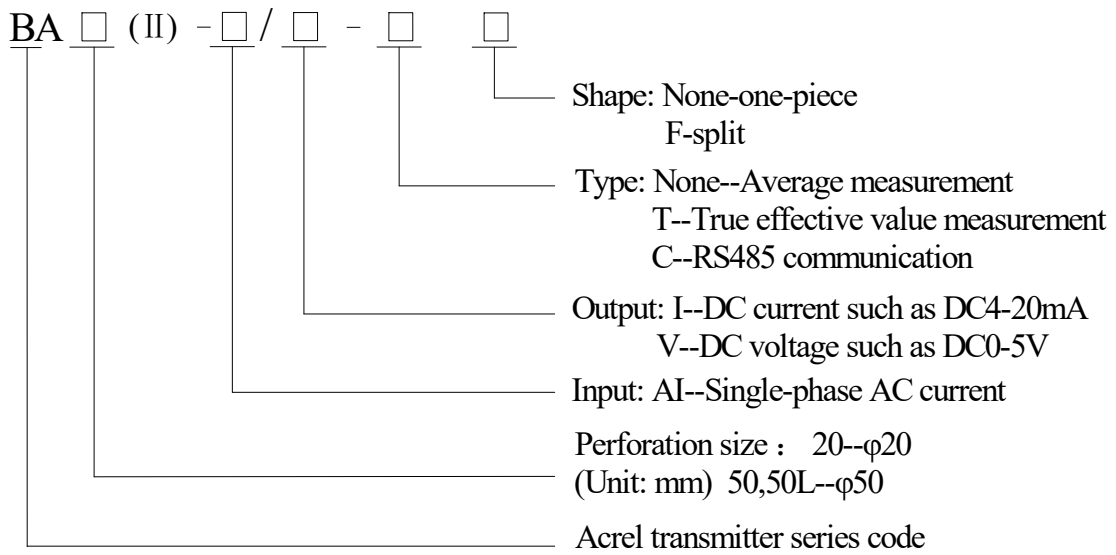

3 产品规格

3 Product specifications

技术参数 Technical parameter		指标 Index
精度等级 Accuracy class		0.5 级 Class 0.5
输入 Input	标称值 Nominal value	BA20(II)-AI 电流 AC 0.5A、50A、200A 等 AC 0~(0.5~200) A Current AC 0.5A, 50A, 200A, etc. AC 0~(0.5~200)A
		BA50(II)-AI 电流 AC 60A、300A、600A 等 AC 0~(60~600) A Current AC 60A, 300A, 600A, etc. AC 0~(60~600)A
		BA50L(II)-AI 电流 AC 0.1A、1A 等 AC 0~(0.1~1) A Current AC 0.1A, 1A, etc. AC 0~(0.1~1)A
	过载 Overload	持续 1.2 倍, 瞬时电流 10 倍/1S Continuous 1.2 times, instantaneous current 10 times/1S
	吸收功率 Absorbed power	≤1VA
频响 Frequency response	25Hz~800Hz, 特别适合工频场合 25Hz~800Hz, especially suitable for industrial frequency occasions	
输出 Output	标称值 Nominal value	DC4~20mA, 或 0~20mA, 0~5V, 0~10V ^① 等 DC4~20mA, or 0~20mA, 0~5V, 0~10V ^① etc.
	负载电阻 Load Resistance	DC12V 供电时, 电流输出时 ≤250 Ω DC24V 供电时, 电流输出时 ≤500 Ω, 电压输出时 ≥1K Ω When DC12V power supply, current output is ≤250 Ω When DC24V power supply, current output is ≤500 Ω, When voltage output is ≥1K Ω
	通讯 Communication	RS485 接口/Modbus-RTU ^② RS485 interface/Modbus-RTU ^②
响应时间 Response time		≤400ms
电源 Power supply	电压 Voltage	DC 12V 或 24V DC 12V or 24V
	功耗 Power consumption	≤1W
绝缘电阻 Insulation resistance		>100M Ω
耐压强度 Compressive strength		输入/输出、电源之间 2.0KV/1min, 50Hz Between input/output and power supply 2.0KV/1min,

		50Hz
温度系数 Temperature Coefficient		-10℃~+55℃时, ≤400ppm/℃ -10℃~+55℃, ≤400ppm/℃
环境 Environment	温度 Temperature	工作: -10℃~+55℃ 储存: -25℃~+70℃ Work: -10℃~+55℃ Storage: -25℃~+70℃
	湿度 Humidity	≤93%RH, 不结露, 无腐蚀性气体场所 ≤93%RH, no condensation, no corrosive gas place
	海拔 Altitude	≤2000m
安装方式 Installation method		TS35 导轨, 或用螺钉固定柜体上 TS35 rail, or use screws to fix the cabinet

注: ①0~10V 输出仅适用于 DC24V 供电;

②通讯功能为可选功能。

Note: ①0~10V output is only suitable for DC24V power supply;

②The communication function is optional.

4 外形及安装

4 Shape and installation

4.1 一体式

(单位: mm)

4.1 One-piece shape

(Unit: mm)

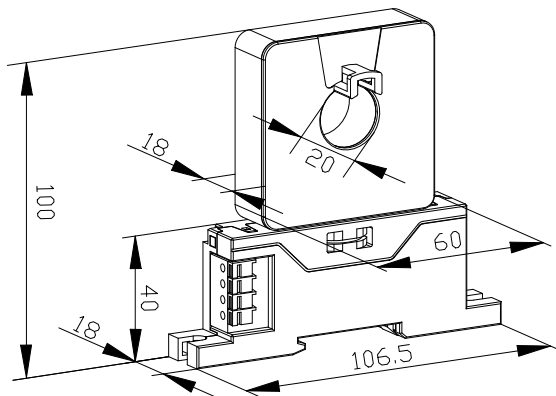

BA20(II)-AI/I(V)

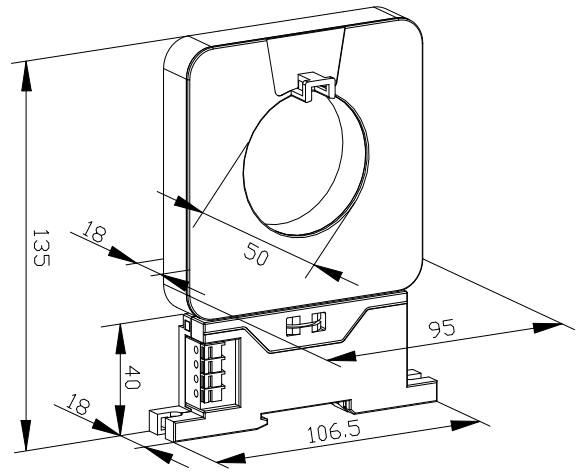

BA50(II)-AI/I(V)、BA50L(II)-AI/I(V)

4.2 分体式

4.2 Split-type shape

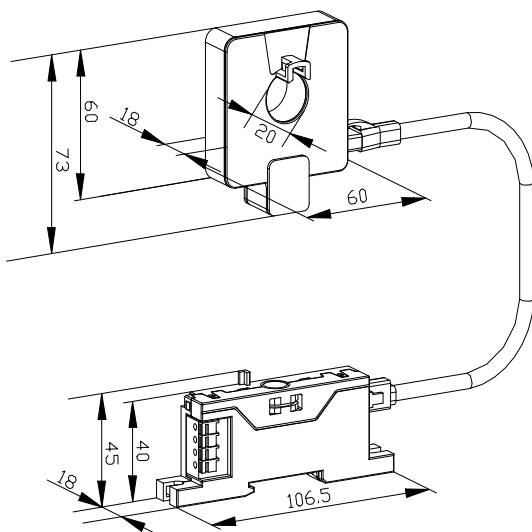

BA20(II)-AI/I(V)-F

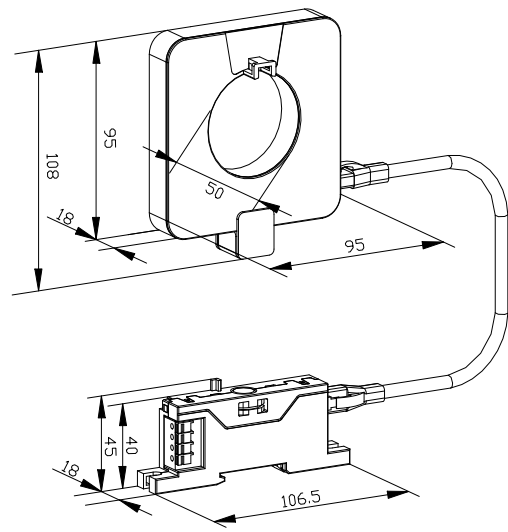

BA50(II)-AI/F、BA50L(II)-AI/I(V)-F

4.3 端子及接线

4.3 Terminals and wiring

4.3.1 电源和模拟量输出

4.3.1 Power supply and analog output

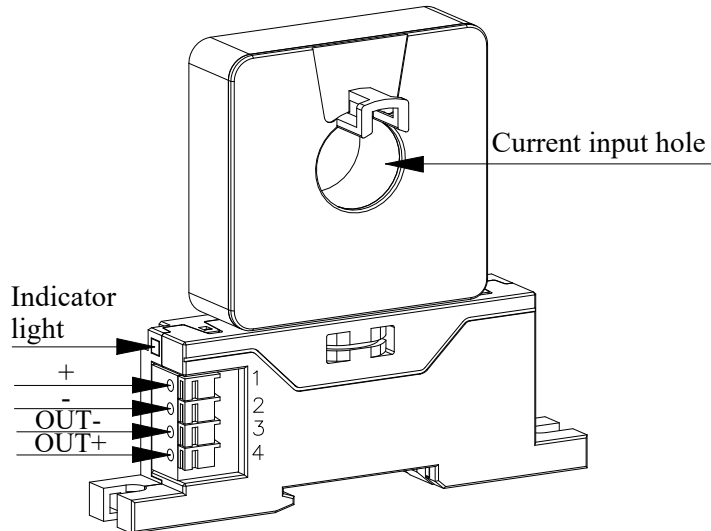
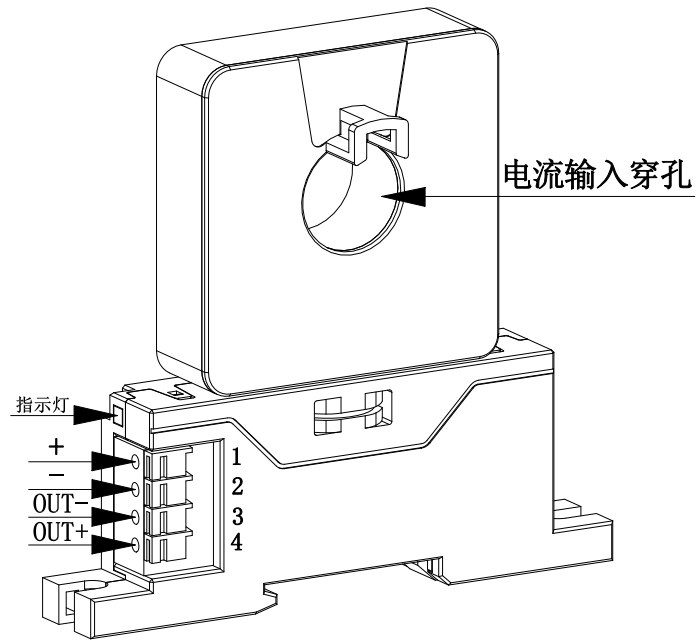

1 —— + 电源正极（注意电源正极与负极不可接反）

2 —— - 电源负极

3 —— OUT- 模拟量输出负

4 —— OUT+ 模拟量输出正

指示灯定义：正常运行，没有连接 485 通讯时，红灯 1s 闪烁一次；

当电流传感器成功连接 485 通讯时，红灯快速闪烁。

1 —— + The positive pole of the power supply (note that the positive pole and the negative pole of the power supply cannot be reversed)

2 —— - Negative power supply

3 —— OUT- Analog output negative

4 —— OUT+ analog output positive

Definition of indicator light: In normal operation, when 485 communication is not connected, the red light flashes once in 1s;

When the current sensor is successfully connected to 485 communication, the red light flashes quickly.

注：仪表接线采用弹簧固定式端子，推荐电源、输出和 RS485 通讯侧连接导线采用横截面积为 0.75mm²屏蔽线。
 Note: The instrument wiring adopts spring-loaded terminal blocks, and it is recommended that the connection wires of the power supply, output and RS485 communication side use shielded wires with a cross-sectional area of 0.75mm².

4.3.2 485 通讯和网口

4.3.2 485 communication and network port

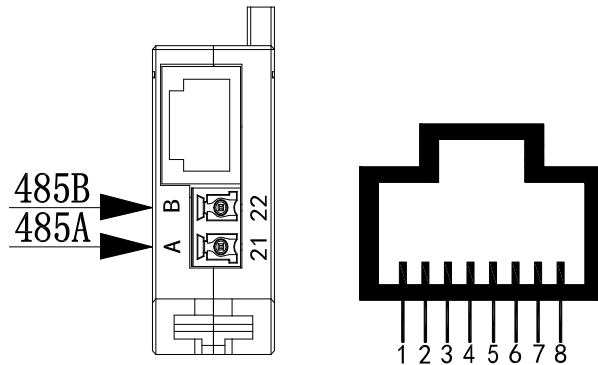

分体式安装时，网口具体定义如下表：

In split installation, the specific definition of the network port is as follows:

1	2	3	4	5	6	7	8
预留 Reserved				互感器信号输入 Transformer signal input		预留 Reserved	互感器信号输入 Transformer signal input

5 通讯协议

5 Communication protocol

本协议规定了智能型 BA 系列电流传感器与数据终端设备进行数据交换的物理连接和通讯协议，其协议方式类同 Modbus_RTU 通信规约。

This protocol specifies the physical connection and communication protocol for data exchange between the intelligent BA series current sensor and the data terminal equipment, and the protocol is similar to the Modbus_RTU communication protocol.

5.1 协议简述

5.1 Brief description of the protocol

智能型 BA 系列电流传感器所使用的通讯协议详细定义了地址码、功能码、校验码的数据序列定义，这些都是特定数据交换的必要内容。该协议在一根通讯线上使用主从应答式连接（半双工），这意味着在一根单独的通讯线上信号沿着相反的两个方向传输。首先，主计算机的信号寻址到一台唯一的终端设备（从机），然后，终端设备发出的应答信号以相反的方向传输给主机。

The communication protocol used by the intelligent BA series current sensor defines the data sequence definition of address code, function code, and check code in detail, which are all necessary content for specific data exchange. This protocol uses a master-slave response connection (half-duplex) on a communication line, which means that the signal is transmitted in two opposite directions on a single communication line. First, the signal from the host computer is addressed to a unique terminal device (slave), and then the response signal from the terminal device is transmitted to the host in the opposite direction.

本协议只允许在主机（PC，PLC 等）和终端设备之间通讯，而不允许独立的终端设备之间的数据交换，这样各终端设备不会在它们初始化时占据通讯线路，而仅限于响应到达本机的查询信号。

This protocol only allows communication between the host (PC, PLC, etc.) and terminal equipment, and does not allow data exchange between independent terminal equipment, so that each terminal equipment will not occupy the communication line when they are initialized, but only in response Inquiry signal

to the machine.

5.2 传输方式

5.2 Transmission method

信息传输为异步方式，并以字节为单位，在主机和从机之间传递的通讯信息是 11 位字格式，包含 1 个起始位、8 个数据位（最小的有效位先发送）、奇偶效验位(无校验)、1 个停止位。

The information transmission is asynchronous, and the unit is byte. The communication information transmitted between the master and the slave is an 11-bit word format, including 1 start bit, 8 data bits (the smallest valid bit is sent first), Parity check bit (no parity), 1 stop bits.

5.2.1 数据帧格式

5.2.1 Data frame format

地址码 Address code	功能码 Function code	数据区 Data area	CRC 效验码 CRC verification code
1 字节 1 byte	1 字节 1 byte	n 字节 n byte	2 字节 2 byte

5.2.2 地址域

5.2.2 Address field

地址域在帧的开始部分，由一个字节（8 位二进制码）组成，十进制为 0~255，在我们的系统中只使用 1~247, 其它地址保留。这些位标明了用户指定的终端设备的地址，该设备将接收来自与之相连的主机数据。每个终端设备的地址必须是唯一的，仅仅被寻址到的终端会响应包含了该地址的查询。当终端发送回一个响应，响应中的从机地址数据便告诉了主机哪台终端正与之进行通信。

The address field is at the beginning of the frame and is composed of one byte (8-bit binary code). The decimal system is 0~255. In our system, only 1~247 are used. Other addresses are reserved. These bits indicate the address of the terminal device designated by the user, which will receive data from the host connected to it. The address of each terminal device must be unique, and only the addressed terminal will respond to the query containing the address. When the terminal sends back a response, the slave address data in the response tells the host which terminal is communicating with it.

5.2.3 功能域

5.2.3 Functional field

功能域代码告诉了被寻址到的终端执行何种功能。下表列出了该系列装置用到的功能码，以及它们的意义和功能。

The function field code tells which function the addressed terminal performs. The following table lists the function codes used in this series of devices, as well as their meanings and functions.

代码 Code	意义 Meaning	行为 Action
03	读数据寄存器 Read data register	获得一个或多个寄存器的当前二进制值 Get the current binary value of one or more registers
16	预置多寄存器 Preset multiple registers	设定二进制值到一系列多寄存器中 Set the binary value to a series of multiple registers

5.2.4 数据域

5.2.4 Data field

数据域包含了终端执行特定功能所需要的数据或者终端响应查询时采集到的数据。这些数据的内容可能是数值、参考地址或者设置值。例如：功能域码告诉终端读取一个寄存器，数据域则需要指明从哪个寄存器开始及读取多少个数据，内嵌的地址和数据依照类型和从机之间的不同内容而有所不同。

The data field contains the data required by the terminal to perform a specific function or the

data collected when the terminal responds to a query. The content of these data may be numerical values, reference addresses or setting values. For example: the function field code tells the terminal to read a register, the data field needs to specify which register to start from and how many data to read. The embedded address and data vary according to the type and the content of the slave.

5.2.5 错误校验域

5.2.5 Error Check Field

该域允许主机和终端检查传输过程中的错误。有时，由于电噪声和其它干扰，一组数据在从一个设备传输到另一个设备时在线路上可能会发生一些改变，出错校验能够保证主机或者终端不去响应那些传输过程中发生了改变的数据，这就提高了系统的安全性和效率，错误校验使用了 16 位循环冗余的方法（CRC16）。

This field allows the host and terminal to check for errors during transmission. Sometimes, due to electrical noise and other interference, a set of data may have some changes on the line when transmitted from one device to another. Error checking can ensure that the host or terminal does not respond to the data that has changed during the transmission. This improves the safety and efficiency of the system, and the error check uses a 16-bit cyclic redundancy method (CRC16).

5.2.6 错误检测的方法

5.2.6 Methods of error detection

错误校验域占用两个字节，包含了一个 16 位的二进制值。CRC 值由传输设备计算出来，然后附加到数据帧上，接收设备在接收数据时重新计算 CRC 值，然后与接收到的 CRC 域中的值进行比较，如果这两个值不相等，就发生了错误。

The error check field occupies two bytes and contains a 16-bit binary value. The CRC value is calculated by the transmitting device and then attached to the data frame. The receiving device recalculates the CRC value when receiving the data, and then compares it with the value in the received CRC field. If the two values are not equal, it will happen error.

CRC 运算时，首先将一个 16 位的寄存器预置为全 1，然后连续把数据帧中的每个字节中的 8 位与该寄存器的当前值进行运算，仅仅每个字节的 8 个数据位参与生成 CRC，起始位和终止位以及可能使用的奇偶位都不影响 CRC。在生成 CRC 时，每个字节的 8 位与寄存器中的内容进行异或，然后将结果向低位移位，高位则用“0”补充，最低位（LSB）移出并检测，如果是 1，该寄存器就与一个预设的固定值（0A001H）进行一次异或运算，如果最低位为 0，不作任何处理。

In the CRC operation, first preset a 16-bit register to all 1s, and then continuously calculate the 8 bits in each byte in the data frame with the current value of the register, only 8 data per byte Bits participate in generating CRC, start bit, stop bit and possible parity bit do not affect CRC. When generating CRC, the 8 bits of each byte are XORed with the contents of the register, and then the result is shifted to the low bit, and the high bit is supplemented with "0", and the least significant bit (LSB) is shifted out and checked. If it is 1, This register is XORed with a preset fixed value (0A001H). If the lowest bit is 0, no processing is done.

上述处理重复进行，直到执行完了 8 次移位操作，当最后一位（第 8 位）移完以后，下一个 8 位字节与寄存器的当前值进行异或运算，同样进行上述的另一个 8 次移位异或操作，当数据帧中的所有字节都作了处理，生成的最终值就是 CRC 值。

The above processing is repeated until 8 shift operations are performed. When the last bit (the 8th bit) is shifted, the next 8-bit byte is XORed with the current value of the register, and the other 8 is also performed. When all the bytes in the data frame are processed, the final value generated is the CRC value.

生成一个 CRC 的流程为：

- (1) 预置一个 16 位寄存器为 0FFFFH（全 1），称之为 CRC 寄存器。

把数据帧中的第一个字节的 8 位与 CRC 寄存器中的低字节进行异或运算，结果存回 CRC 寄存器。

将 CRC 寄存器向右移一位，最高位填以 0，最低位移出并检测。

如果最低位为 0:重复第三步(下一次移位);如果最低位为 1:将 CRC 寄存器与一个预设的固定值(0A001H)进行异或运算。

重复第三步和第四步直到 8 次移位。这样处理完了一个完整的八位。

(2) 重复第 2 步到第 5 步来处理下一个八位，直到所有的字节处理结束。

最终 CRC 寄存器的值就是 CRC 的值。

The process of generating a CRC is:

(1) Preset a 16-bit register as 0FFFFH (all 1s), which is called CRC register. . XOR the 8 bits of the first byte in

the data frame with the low byte in the CRC register, and store the result back to the CRC register. Shift the

CRC register one bit to the right, fill the highest bit with 0, and shift out the lowest bit and check. If the lowest

bit is 0: repeat the third step (the next shift); if the lowest bit is 1: XOR the CRC register with a preset fixed

value (0A001H). Repeat the third and fourth steps until 8 shifts. A complete eight bits are processed in this

way.

(2) Repeat steps 2 to 5 to process the next eight bits until all bytes are processed.

The final CRC register value is the CRC value.

此外还有一种利用预设的表格计算 CRC 的方法，它的主要特点是计算速度快，但是表格需要较大的存储空间，该方法此处不再赘述，请参阅相关资料。

In addition, there is a method for calculating CRC using a preset table. Its main feature is fast calculation speed, but the table requires a larger storage space. This method will not be repeated here, please refer to related materials.

5.3 功能码简介

5.3 Introduction to function codes

5.3.1 功能码 03H: 读寄存器

5.3.1 Function code 03H: read register

此功能允许用户获得设备采集与记录的数据及系统参数。主机一次请求的数据个数没有限制，但不能超出定义的地址范围。

This function allows users to obtain the data and system parameters collected and recorded by the device. The number of data requested by the host at one time is unlimited, but it cannot exceed the defined address range.

下面的例子是从 01 号从机读 2 个采集到的基本数据（数据帧中每个地址占用 2 个字节）电流、电流小数位，其中电流 I 的地址为 0006H, 电流小数位 I_Point 的地址为 0007H。

The following example is reading 2 basic data collected from slave 01 (each address in the data frame occupies 2 bytes) current, current decimal places, the address of current I is 0006H, the address of current decimal place I_Point For 0007H.

主机发送 Host send		发送信息 Send Message
地址码 Address code		01H
功能码 Function code		03H
起始 地址	高字节	00H

从机返回 Slave return		返回信息 Returned messages
地址码 Address code		01H
功能码 Function code		03H
字节数		04H

Starting address	High byte	
	低字节 Low byte	06H
寄存器数量 Number of registers	高字节 High byte	00H
	低字节 Low byte	02H
CRC 校验码 CRC verification code	低字节 Low byte	24H
	高字节 High byte	0AH

Number of bytes		
寄存器 数据 (电流) Register data (Current)	高字节 High byte	13H
	低字节 Low byte	88H
寄存器 数据 (电流小数位) Register data (Current decimal places)	高字节 High byte	00H
	低字节 Low byte	01H
CRC 校验码 CRC verification code	低字节 Low byte	BFH
	高字节 High byte	5DH

5.3.2 功能码 10H: 写寄存器

5.3.2 Function code 10H: write register

功能码 10H 允许用户改变多个寄存器的内容, 该仪表中系统参数、开关量输出状态等可用此功能号写入。主机一次最多可以写入 16 个(32 字节)数据。

Function code 10H allows users to change the contents of multiple registers. The system parameters and switch output status of the instrument can be written with this function number. The host can write up to 16 (32 bytes) data at a time.

下面的例子是预置地址为 01 的仪表修改 025AH 仪表地址、波特率。

The following example is to modify the address and baud rate of the 025AH meter with the preset address of 01.

主机发送 Host send		发送信息 Send Message	从机返回 Slave return		返回信息 Returned messages
地址码 Address code		01H	地址码 Address code		01H
功能码 Function code		10H	功能码 Function code		10H
起始地址 Starting address	高字节 High byte	02H	起始地址 Starting address	高字节 High byte	02H
	低字节 Low byte	5AH		低字节 Low byte	5AH
寄存器数量 Number of registers	高字节 High byte	00H	寄存器数量 Number of registers	高字节 High byte	00H
	低字节 Low byte	01H		低字节 Low byte	01H
字节数 Number of bytes		02H	CRC 校验码 CRC verification code	低字节 Low byte	20H
025AH 待写入数据 025AH Data to be	高字节 High byte	01H		高字节 High byte	62H

written	低字节 Low byte	00H
CRC 校验码 CRC verification code	低字节 Low byte	88H
	高字节 High byte	FAH

5.4 通讯地址表

5.4 Communication address table

序号 Serial number	字地址 Word address	名称 Name	解释 Explanation	读/ 写 Read /write	字长 Word length	单位 Unit	数据类型 Type of data	备注 Remarks
1	0x06	I	电流 Current	R	1	A	Uint16	0-9999
2	0x07	I_Point	电流小数位 Current decimal places	R	1	---	Uint16	0-7
3	0x25A 高位 0x25a high bit	Addr	通讯地址 postal address	R/W	1	---	Uint16	1-247 广播地址 254 Broadcast address 254
	0x25A 低位 0x25a low bit	Baud	波特率 Baud rate	R/W		bps		0-5:9600, 19200, 38400, 1200, 2400, 4800
4	0x25B 高位 0x25b high bit	预留 Reserv ed	---	R/W	1	---	Uint16	0-3: 0: 无校验 8 数据位 1 停止位 1: 无校验 8 数据位 2 停止位 2: 奇校验 8 数据位 1 停止位 3: 偶校验 8 数据位 1 停止位
	0x25B 低位 0x25b low bit	Check	校验位 Check bit	R/W		---		0-3: 0: No parity 8 data bits 1 stop bit 1: No parity 8 data bits 2 stop bits 2: Odd parity 8 data bits 1 stop bit 3: Even parity 8 data bits 1 stop bit

5.5 电流信号解析

5.5 Current signal analysis

电流实际值 = $I * 10^{(I_Point-3)}$ ，如读出电流 06H 数据为 25，电流小数位 07H 处数据为 2，此时实际电流 = $25 * 10^{(2-3)} = 2.5A$ 。

Actual current value = $I * 10^{(I_Point-3)}$, if the reading of current at 06H is 25 and the decimal value of current at 07H is 2, then the actual current will equal to $25 * 10^{(2-3)} = 2.5A$.

6 订货范例

6 Order example

BA20(II)-AI/I 一体式平均值交流电流传感器

辅助电源: DC 12V

输入: AC 5A

输出: DC 4-20mA

精度: 0.5 级

BA20(II)-AI/I One-piece average AC current sensor

Power supply: DC 12V

Input: AC 5A

Output: DC 4-20mA

Accuracy: Class 0.5

BA50(II)-AI/V-CTF 分体式真有效值交流电流传感器

辅助电源: DC 24V

输入: AC 100A

输出: DC 0 -5V

精度: 0.5 级

通讯: RS485

BA50(II)-AI/V-CTF Split type true effective value AC current sensor

Power supply: DC 24V

Input: AC 100A

Output: DC 0 -5V

Accuracy: Class 0.5

Communication: RS485

BA50L(II)-AI/I-C 一体式平均值交流剩余电流传感器

辅助电源: DC 12V

输入: AC 1A

输出: DC 4 -20mA

精度: 0.5 级

通讯: RS485

BA50L(II)-AI/I-C One-piece average AC residual current sensor

Power supply: DC 12V

Input: AC 1A

Output: DC 4 -20mA

Accuracy: 0.5 level

Communication: RS485

说明书修订记录

日期	旧版本	新版本	修改内容
2020-9-16	V1.0		第一次修订
2021-4-6	V1.0	V1.1	5.5 电流信号解析 电流实际值由 $I * 10^{(4-I_Point)}$ 改为 $I * 10^{(I_Point-3)}$
2021-12-22	V1.1	V1.2	4.3.1 增加指示灯定义：正常运行，没有连接 485 通讯时，红灯 1s 闪烁一次；当电流传感器成功连接 485 通讯时，红灯快速闪烁。
2022-4-26	V1.2	V1.3	5.2 停止位由 2 改为 1
2022-5-23	V1.3	V1.4	5.4 序号 2 的备注改为 0-7；5.5 电流信号解析加例子：如读出电流 06H 数据为 25，电流小数位 07H 处数据为 2，此时实际电流 $= 25 * 10^{(2-3)} = 2.5A$
2022-11-11	V1.4	V1.5	4.3.1 增加接线注意事项