

472



ARD2M

Motor Protector Operating

Manual V1.5

ACREL Co., Ltd

Declaration

All rights reserved. Without the written permission of the Company, the contents of any paragraph or section in this manual shall not be copied, copied or disseminated in any form. Otherwise, all consequences shall be borne by the violator.

Our company reserves all legal rights.

Our company reserves the right to modify the product specifications described in this manual without prior notice. Before placing an order, please consult your local agent for new specifications of this product.

Catalog

1 Overview.....	- 1 -
2 Product Features.....	- 1 -
3 Model Description.....	- 1 -
4 Main parameters.....	- 2 -
5 Overall dimensions and installation.....	- 4 -
6 Protection function description.....	- 9 -
7 Function setting and description.....	- 23 -
8 Communication Settings and instructions.....	- 34 -
9 Features and Functions.....	- 59 -
10 Examples of ordering.....	- 61 -

1 Overview

The ARD2M motor protector (hereinafter referred to as the protector) is suitable for low-voltage motor circuits with rated voltage up to 380V and integrates protection, measurement, control, communication, operation and maintenance. Its perfect protection function ensures the safe operation of the motor, with logic programmable function, can meet a variety of control methods.

The product adopts split structure, which is composed of main body, panel, mutual inductor and optional communication module, and can adapt to the installation of various cabinets.

Product Implementation standards:

——**GB/T14048.4-2020** Low-voltage switchgear and control gear -- Part 4-1: Contactors and motor starters -- Electromechanical contactors and motor starters (including motor protectors);

——JB/T 10736-2007 Low voltage motor protector.

2 Product Features

- Support power parameter measurement (U, I, P, Q, S, PF, F, EP, EQ), voltage and current imbalance degree, voltage and current positive sequence, negative sequence, zero sequence component, three-phase voltage phase Angle, residual current.
- Protection functions include overload inverse time, overload definite time, grounding, starting timeout, leakage, underload, locked-rotor, obstruction, short circuit, phase, overflow, imbalance (current, voltage, power, less power, over voltage, under voltage, phase sequence, temperature, external fault, tE time, running time alarm, fault alarm.
- 8 channels programmable DI input, the default use of DC24V power supply, or external active wet contact can be selected (see the selection table).
- 5 programmable DO output, to meet the direct starting, star - triangle starting, auto-transformer starting, and other starting modes, can be through the communication bus to achieve the master station to the motor remote control "start/stop".
- Optional anti-shaking function: support immediate restart of shaking power and restart of voltage loss.
- MODBUS_RTU and PROFIBUS DPV1 communication modules are available for selection. 2 MODBUS_RTU communication channels or MODBUS_RTU+PROFIBUS DPV1 communication modules can be chosen.
- Optional 1 channels DC4-20MA analog output interface, connected with DCS system, can realize the monitoring of field equipment.
- With fault record, start record, stop record, DI displacement record, restart record and other records of various events, you can view a number of motor operation and maintenance information.
- The display interface supports Chinese/English LIQUID crystal display

3 Model Description

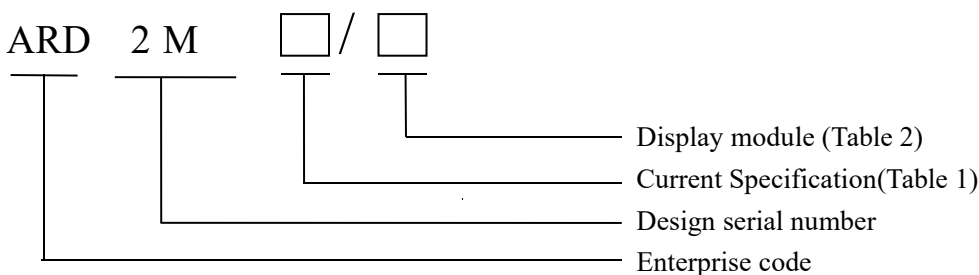

The corresponding relation between ARD2M current specification and the rated current and power of the applicable motor is shown in Table 1:

Table 1

Protector current specification (A)	Ratio setting	Primary side coil number of transformer	Applicable scope of motor (kW)	Suitable for motor Rated current range (A)
1	Support	1circle	0.12-999	0.1-1.6
5		1cirlice	0.12-999	1.6-6.3
25	Does not support	1cirlice	3-11	6.3-25
100		1circle	15-45	25-100
250		1circle	55-132	63-250
800		1circle	160-250	250-800

Remarks: The protectors of 1A and 5A specifications realize the protection and control of motors with current range of 0.1-5000A and 0.5-5000A by connecting current transformers with secondary output of 1A and 5A signals.

Additional function of ARD2M are shown in Table 2:

Table 2

Additional function	code	Additional function	code
Energy metering	Ep	SOE Event record	SR
4-20mA analog output	M	1channel Modbus-RTU communication	C
Anti - electric shock function	SU	Temperature protection	T
Leakage protection	L	1channel Profibus-DP communication	CP
2 channels Modbus-RTU communication	CC		

Remarks:

(1)Integrated current transformer is used for integrated protector with current specification of 100A and below; The split current transformer is used for the current specification of 100A and below;

250A and 800A current specifications use another type of split current transformer. For the external dimensions of the transformer, please refer to the "external dimensions and installation".

(2)The temperature measurement support sensor type is PTC or NTC or PT100.

(3)After the leakage function (L) is selected, each protector is equipped with a leakage transformer. The dimensions of the leakage transformer are shown in the section "overall dimensions and installation". Leakage transformer is equipped with 2m ± 10cm secondary line as standard. If you need other length, please contact the manufacturer.

4 Main parameters

4.1 Technical indicators

ARD2M technical indicators are shown in Table 3:

Table 3

Technical parameters	Technical indicators	
Protector auxiliary power supply	AC85-265V/DC100-350V	
Rated working voltage of the motor	AC220V / 380V, 50Hz / 60Hz	
Rated operation current of the motor	1 (0.1A-1.6A)	Integrated/Split current transformer
	5 (1.6A-6.3A)	
	25(6.3A-25A)	
	100(25A-100A)	
	250(63A-250A)	Split current transformer
	800(250A-800A)	
Relay output contact capacity	Impedance load	AC250V、10A
Switching input	8 channels of passive dry contact (active DC110V, DC220V, AC220V input can be optional)	
Communication	RS485 Modbus_RTU, Profibus DP	
Environment	Working temperature	-10°C~55°C
	Storage temperature	-25°C~70°C
	Relative temperature	≤95 % No condensation, no corrosive gas
	Altitude	≤2000m
Pollution levels	3 level	
Protection grade	IP65(installed on the cabinet panel)	
Installation category	III 级	

4.2 Functional configuration

ARD2M Functional configuration shown in Table 4:

Table 4

Function	Type	Functional configuration	
		Standard function	Optional function
Protection function	Fixed time overload	√	
	Inverse time overload	√	
	Starting timeout	√	
	Phase loss	√	
	Voltage unbalance	√	
	Current unbalance	√	
	Locked-Rotor	√	
	underload	√	
	External fault	√	
	Block	√	
	Temperature protection(PTC/NTC)		√
	Residual current(One grounding)	√	

	only)	leakage		√(leakage)
	Phase sequence		√	
	Under voltage		√	
	Over voltage		√	
	Under power		√	
	Over power		√	
	Te time protection		√	
	Overflow protection		√	
	Alarm of starting times		√	
	Running time alarm		√	
	Fault frequency alarm		√	
Control mode	Protection mode		√	
	Direct start mode			
	Two-step mode		√	
	Two-speed mode			
	Voltage loss restart		√	
Communication function	1 channel Modbus-RTU communication		√	
	2 channels Modbus-RTU communication			√
	1 channel Profibus-DP communication			√
Switching input	8 channel DI		√	
Relay output	5 channel DO		√	
Analog output	1 channel DC4-20mA			√
Event record	Start record, stop record, DI displacement record, restart record, (support communication transmission)		√	

5 Overall dimensions and installation

5.1 Composition

The product composition of ARD2M is shown in Figure 1, Figure 2:

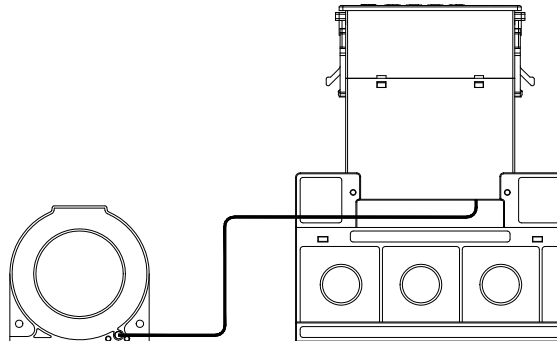

Figure1 The composition of integrated protector

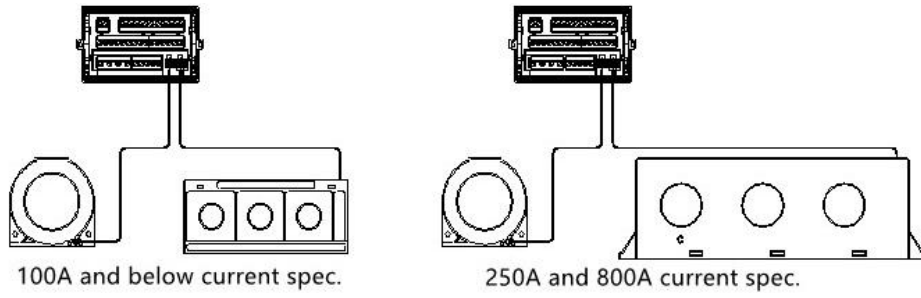

Figure 2 The composition of split protector

5.2 Panel size and opening (Unit: mm)

The shape and opening size are shown in Figure 3,4::

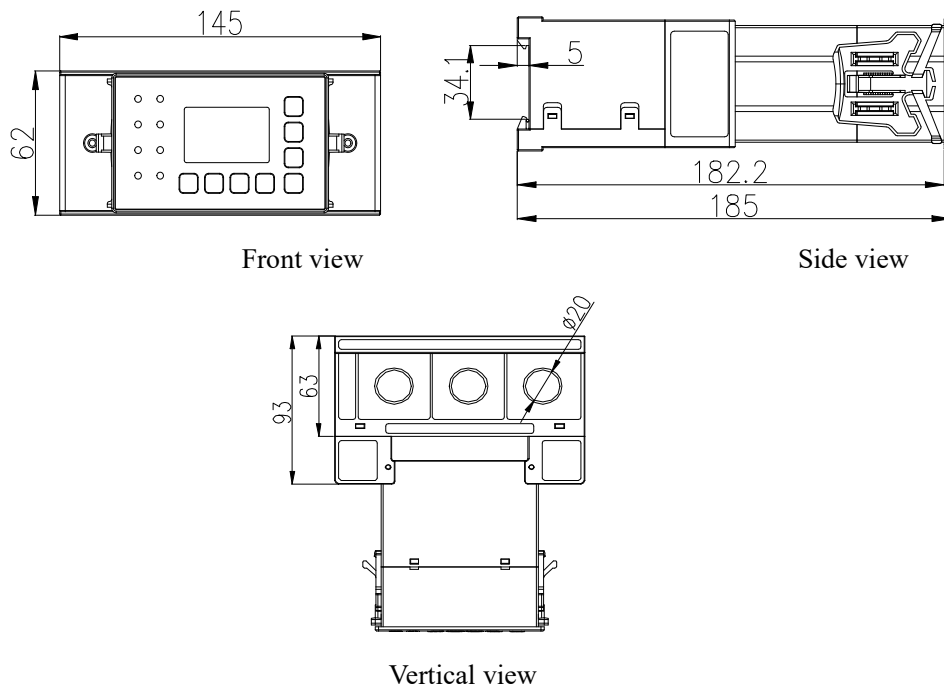

Figure 3 Panel size of integrated protector ARD2M

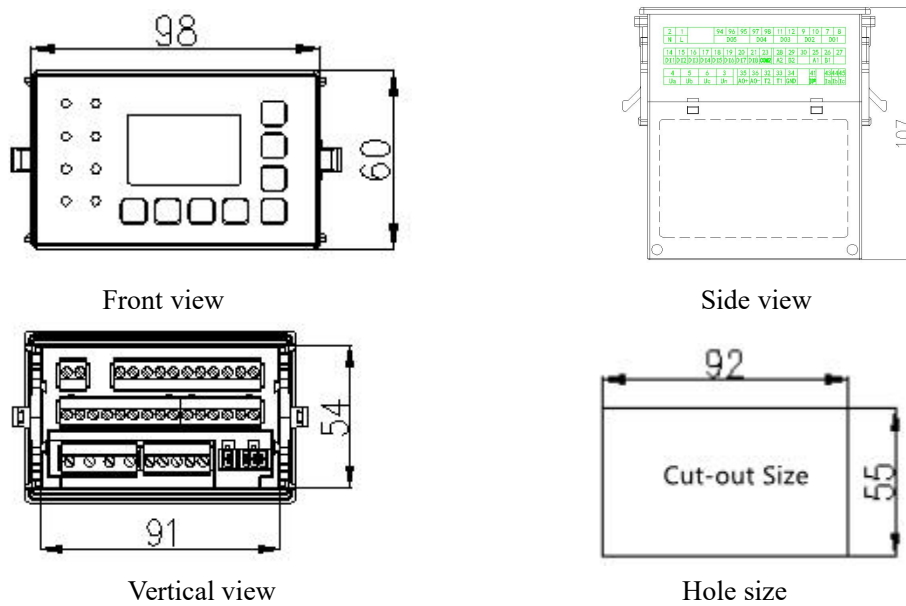

Figure 4 Panel size of split protector ARD2M

5.3 Size of installation of current transformer (unit: mm)

5.3.1 The external dimensions of Integrated/split current transformer (100A and below current specification) are shown in figure 5 (Unit: mm):

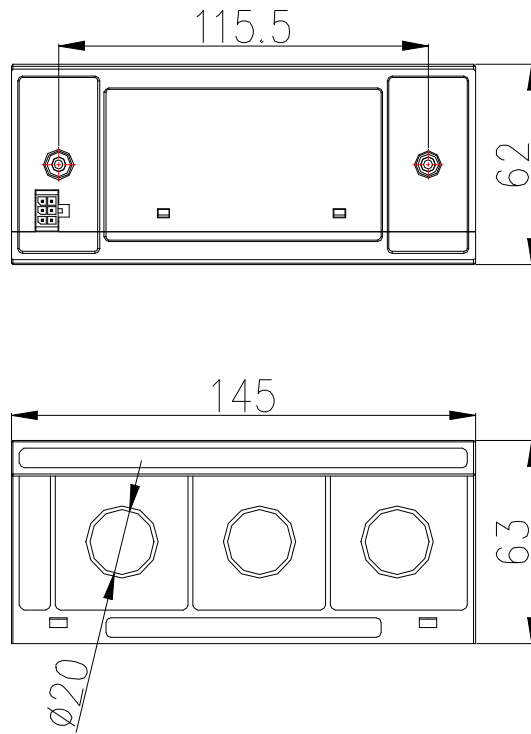

Figure 5 The external dimensions of Integrated/split current transformer (100A and below current specification)

5.3.2 The external dimensions of split current transformer (250A and 800A current specification) are shown in figure 6 (Unit: mm):

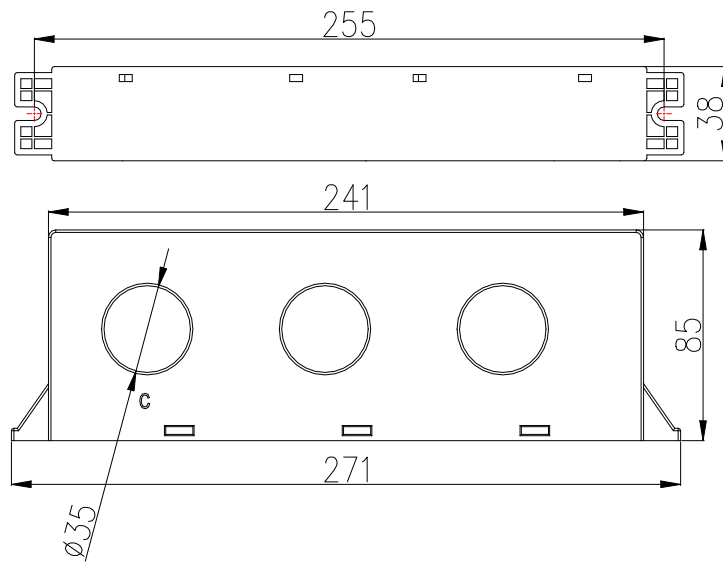

Figure 6 The external dimensions of split current transformer (250A and 800A current specification)

5.3.3 The external dimensions of leakage current transformer are shown in figure 7 and table 5 (Unit: mm):

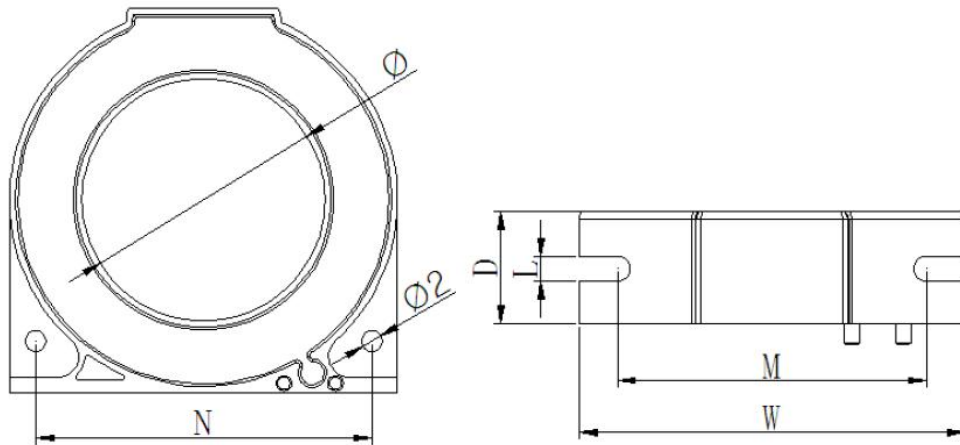

Figure 7 The external dimensions of leakage current transformer

The leakage transformer is equipped with a secondary wire of $2m \pm 10cm$. If other lengths are needed, please contact the manufacturer

Table 5

Spec.	dimension	Overall size(mm)			Go through size(mm)	Installation size(mm)				Tolerance(mm)	Weight (g)
		W	H	D	Φ	M	N	L	Φ2		
L-45		75	75	22	46	65	65	4.3	4	±1	200 ± 10
L-80		120	120	23	81	105	105	4.4			380 ± 10
L-100		140	140	23	100	124	124	4.6			460 ± 10

5.4 Terminal

The wiring terminal arrangement of the ARD2M main body is shown in Figure 8

2	1				94	96	95	97	98	11	12	9	10	7	8	
N	L				D05			D04		D03		D02		D01		
14	15	16	17	18	19	20	21	23		28	29	30	25	26	27	
DI1	DI2	DI3	DI4	DI5	DI6	DI7	DI8	COM2		A2	B2		A1	B1		
4	5	6	3			35	36	32	33	34		41		43	44	45
Ua	Ub	Uc	Un			A0+	A0-	T2	T1	GND		I0*		Ia	Ib	Ic

Figure 8 The wiring terminal arrangement of ARD2M CP

2	1				94	96	95	97	98	11	12	9	10	7	8	
N	L				D05			D04		D03		D02		D01		
14	15	16	17	18	19	20	21	23		28	29	30	25	26	27	
DI1	DI2	DI3	DI4	DI5	DI6	DI7	DI8	COM2		B2	A2		A1	B1		
4	5	6	3			35	36	32	33	34		41		43	44	45
Ua	Ub	Uc	Un			A0+	A0-	T2	T1	GND		I0*		Ia	Ib	Ic

Figure 9 The wiring terminal arrangement of ARD2M CC

See Table 6 for the ARD2M terminal number and function definition:

Table 6

Terminals NO.	Function definition	Remark
1	Power input L (+ at DC time)	The auxiliary power supply is connected to the two terminals
2	Power input N (- at DC time)	
3	Un input	Three-phase voltage input
4	Ua Phase voltage input	
5	Ub Phase voltage input	
6	Uc Phase voltage input	
7、8	DO1, Start 1 output	5-channels programmable relay output (DO) (The function is defined as factory default setting, which can be set by users according to their needs)
9、10	DO2, Start 2 output	
11、12	DO3, Alarm output	
97、98	DO4, Trip output, normally open point signal	
94、95、96	DO5, Trip output, normally closed+ normally open with common end	
14	DI1, Stop signal input	
15	DI2, Start 1 signal input	
16	DI3, Start 2 signal input	
17	DI4, Emergency stop signal input	
18	DI5, Reset signal input	
19	DI6, Control permission 1 input	
20	DI7, Control permission 2 input	
21	DI8, External fault signal input	
23	COM2, DI Input common terminal	
35	Analog output AO+	4-20mA analog output
36	Analog output common end AO-	
25	A1	First channel MODBUS communication
26	B1	
28	A2	Second channel MODBUS communication
29	B2	
32	T1(PTC input A)	Temperature protection (thermistor input)
33	T2(PTC input B)	
34	GND	
41	IO*leakage current input	Leakage current input
43	Ia Phase current input	
44	Ib Phase current input	
45	Ic Phase current input	

Note: When the second channel communication, the terminal 28 is B2, he terminal 28 is A2.

6 Protection function description

The default action stages of each protection are shown in Table 7:

Table 7

Protection type	Default active period
Overvoltage, undervoltage, voltage imbalance, phase sequence, external fault, overflow protection, starting times, fault times, running time, PTC/NTC temperature protection	whole course
Reverse time overload, locked rotor, phase break, leakage, grounding, starting timeout, short circuit, overflow protection, Overvoltage, undervoltage, voltage imbalance, phase sequence, external fault, number of starts, number of faults, running time, PTC/NTC temperature protection, fixed time overload	When starting
Reverse time-limit overload, blocking, phase break, current imbalance, leakage, grounding, constant time-limit overload, underload, short circuit, overflow protection, overvoltage, undervoltage, voltage unbalance, phase sequence, underpower, overpower, external fault, PTC/NTC temperature protection, number of starts, number of faults, running time	In operation

6.1 Inverse time overload protection

When the motor runs for a long time in excess of its rated current under excessive load, it will overheat the motor, reduce insulation and burn it out. The protector calculates the heat capacity of the motor according to its heating characteristics and simulates its heating characteristics to protect the motor.

The starting condition of reverse time-limit overload protection is that the maximum three-phase current reaches the set overload starting value, and the default overload starting value is 1.2 times the motor's rated current.

The current-time comparison table of overload protection is shown in Table 8, and the overload characteristic curve (K curve) is shown in Figure 10:

Table 8

Optional tripping curve grade K	1	2	3	5	10	15	20	25	30	35	40
Tripping delay(S)tolerance $\pm 10\%$	Three - phase balanced load, starting from the cold state										
Rated value $I_e \times 1.2$	25	50	75	125	250	375	500	625	750	875	1000
$\times 1.5$	16	32	48	80	160	240	320	400	480	560	640
$\times 2$	9	18	27	45	90	135	180	225	270	315	360
$\times 3$	4	8	12	20	40	60	80	100	120	140	160
$\times 4$	2.26	4.52	6.78	11.3	22.5	33.8	45	56.3	67.5	78.8	90
$\times 5$	1.44	2.88	4.32	7.2	14.4	21.6	28.8	36	43.2	50.4	57.6
$\times 6$	1	2	3	5	10	15	20	25	30	35	40

×7.2	0.7	1.4	2.1	3.5	6.9	10.4	13.9	17.4	20.8	24.3	27.8
------	-----	-----	-----	-----	-----	------	------	------	------	------	------

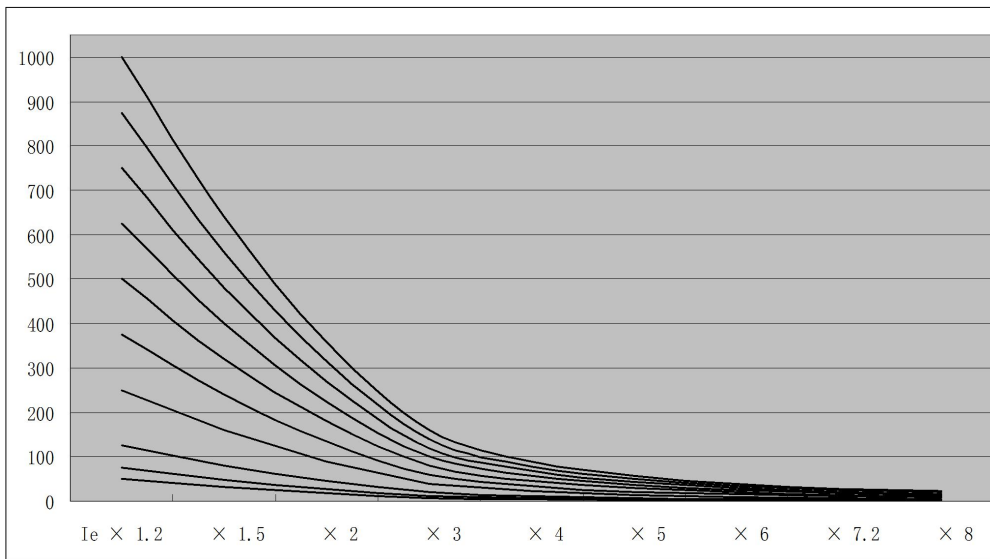
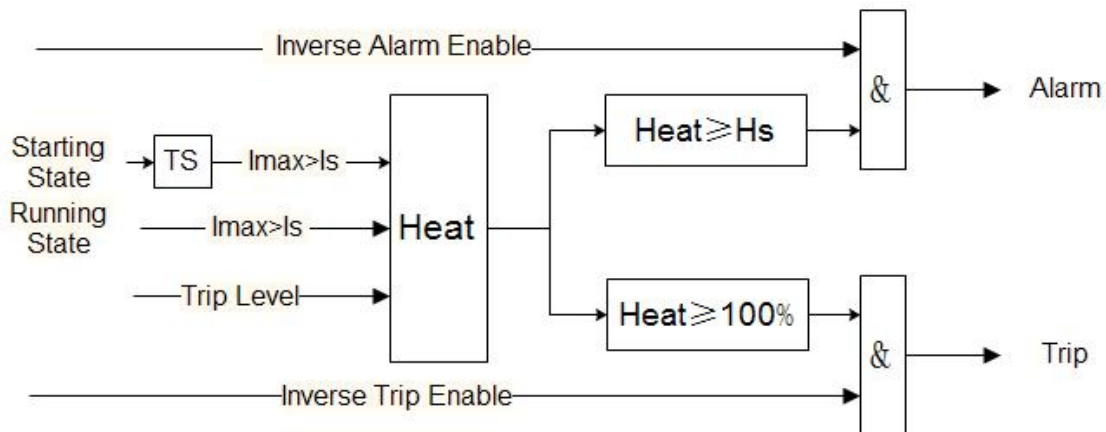

Figure 10 Characteristic curve of overload (K curve)

Inverse time overload protection improves manual and automatic reset options. When "automatic" is selected, after the overload trip of the motor, the heat capacity will be automatically reset to less than 15%, and the restart operation can be allowed without the need for further reset operation; When "manual" is selected, after the motor overload trip, the heat capacity will be reduced to less than 15%. Manual manual reset is required, otherwise the restart operation is not allowed.



Note:

I_{max} : Maximum three-phase current

I_s : Overload starting fixed value

Heat: Percentage heat capacity

H_s : Heat capacity alarm value

TS: Starting shield time

tE Time protection

For the increased safety type motor, after the ac winding reaches the rated operating stable temperature at the highest ambient temperature, the time required from the beginning of passing through the blocking current until it rises to the limit temperature is tE time. The tE time of the increased safety motor is usually provided by the motor manufacturer, and the user can find this data on the motor nameplate.

It provides thermal overload protection of disconnecting the power supply of the motor within tE time during lock-in. It is only put in after the motor is started, with an independent delay timer. The motion delay comparison of tE

protection characteristic curve is shown in Table 9, and the curve is shown in Figure 11:

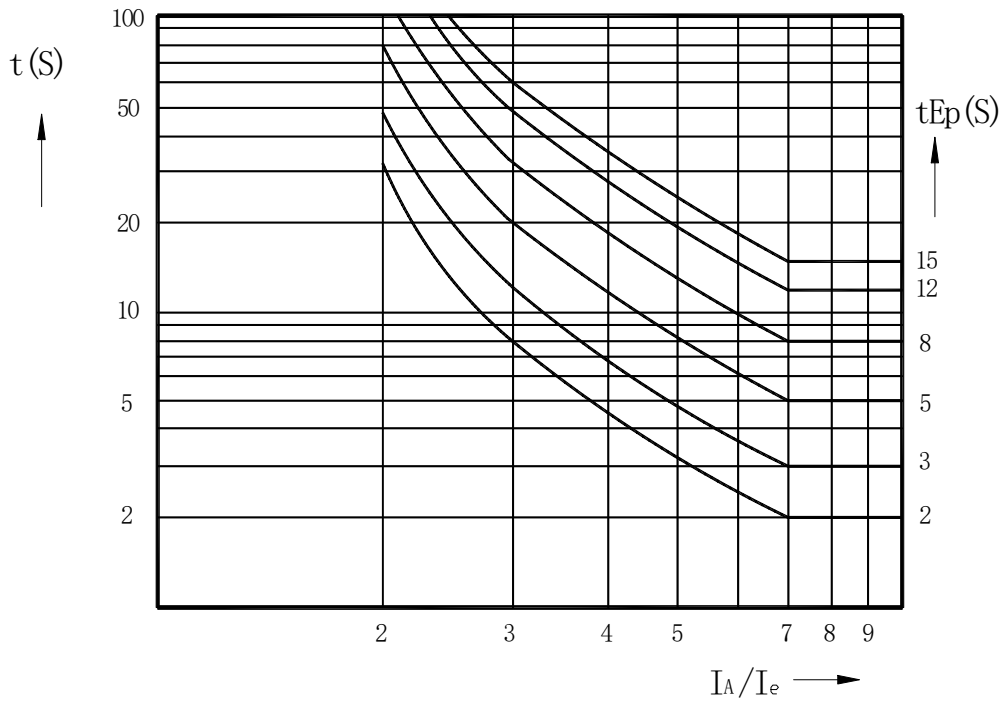

Figure 11 tE Protection delay to blocking current ratio I_A/I_e Current-time characteristic curve

Instructions: t_{Ep} : 7 times of the rated current allowed lock-in time; I_A : Locked-rotor current;
 I_e : Rated current of the motor.

Table 9

t_{Ep}^{Set} I_A/I_e	2(S)	3(S)	4(S)	5(S)	6(S)	8(S)	10(S)	12(S)	15(S)
2.0	32	48	64	80	96	128	160	192	240
2.2	20.27	30.4	40.54	50.67	60.81	81.08	101.35	121.62	152.02
2.4	14.75	22.12	29.5	36.87	44.25	59	73.75	88.5	110.63
2.6	11.54	17.32	23.09	28.87	34.64	46.19	57.74	69.29	86.62
2.8	9.46	14.19	18.92	23.65	28.39	37.85	43.31	56.78	70.97
3.00	8	12	16	20	24	32	40	48	60
3.20	6.91	10.37	13.83	17.29	20.75	27.67	34.59	41.51	51.88
3.40	6.08	9.13	12.17	15.22	18.26	24.35	30.44	36.52	45.66
3.60	5.43	8.14	10.86	13.58	16.29	21.72	27.16	32.59	40.74
3.80	4.9	7.35	9.8	12.25	14.7	19.6	24.5	29.41	36.76
4.00	4.46	6.69	8.93	11.16	13.39	17.86	22.32	26.79	33.48
4.20	4.09	6.14	8.19	10.24	12.29	16.39	20.49	24.59	30.74
4.40	3.79	5.68	7.58	9.47	11.37	15.06	18.95	22.74	28.42
4.60	3.52	5.28	7.05	8.81	10.57	14.1	17.62	21.15	26.43
4.80	3.29	4.94	6.59	8.24	9.88	13.08	16.48	19.77	24.72
5.00	3.09	4.64	6.19	7.74	9.29	12.38	15.48	18.58	23.22
5.20	2.92	4.38	5.84	7.3	8.76	11.68	14.6	17.53	21.91
5.40	2.76	4.15	5.53	6.91	8.3	11.07	13.83	16.6	20.75

5.60	2.63	3.94	5.26	6.57	7.89	10.52	13.15	15.78	19.73
5.80	2.5	3.76	5.01	6.27	7.52	10.03	12.54	15.05	18.81
6.00	2.4	3.6	4.8	6	7.2	9.6	12	14.4	18
6.20	2.3	3.45	4.6	5.75	6.9	9.2	11.51	13.81	17.26
6.40	2.21	3.32	4.42	5.53	6.64	8.85	11.07	13.28	16.6
6.60	2.13	3.2	4.27	5.33	6.4	8.54	10.67	12.81	16.01
6.80	2.06	3.09	4.12	5.16	6.19	8.25	10.32	12.38	15.48
7.00	2	3	4	5	6	8	10	12	15
8.00	2	3	4	5	6	8	10	12	15
9.00	0.2	0.2	0.2	0.2	0.2	0.2	0.2	0.2	0.2

Note:

(1)The action time of tE protection = the action time /2×tEp when tEp is 2 (S)

(2)When tE is set at 5 (S), the tE value determined according to the starting current ratio IA/ Ie is in accordance with IEC79-7 and GB3836.3-2000 standards. When it is used for tE time protection of increased safety motor, its inverse time overload protection can be set according to this characteristic curve.In order to ensure that the power is disconnected before tE time during the motor's lock-in, the inverse time curve of the overload protection device should be lowered by about 15%.

(3)The action time of tE protection is achieved by setting "motor type" and "trip level", and the corresponding trip curve is selected by setting tEp (trip level) according to Table 9.(When the motor type is selected as "increased security motor", the tripping level will automatically change to tEp setting;Otherwise, the trip curve is the reverse time-limit overload trip curve of ordinary motor.

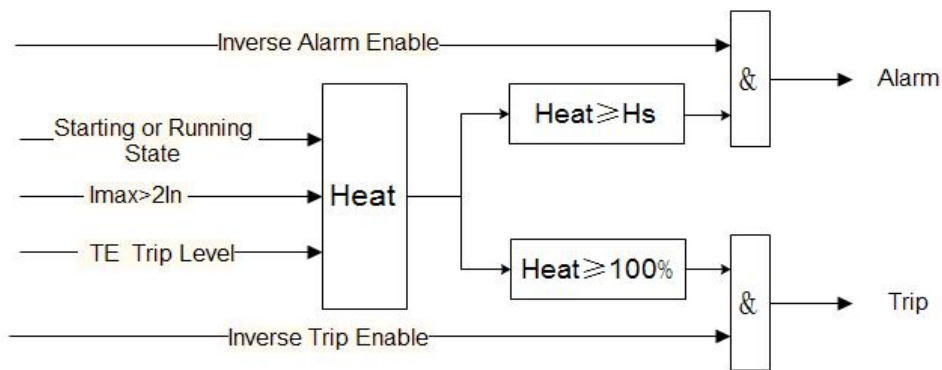

Note:

Imax:Maximum three-phase current

In:Rated current

Heat:Percentage heat capacity

Hs:Heat capacity alarm value

6.2 Start timeout protection

When the starting time of the motor reaches the starting time set by the user, the average three-phase current does not drop below the set tripping threshold, trigger the starting timeout protection, issue tripping command, and stop the motor operation.For the increased safety motor, the starting time setting shall not exceed 1.7 times tE time.

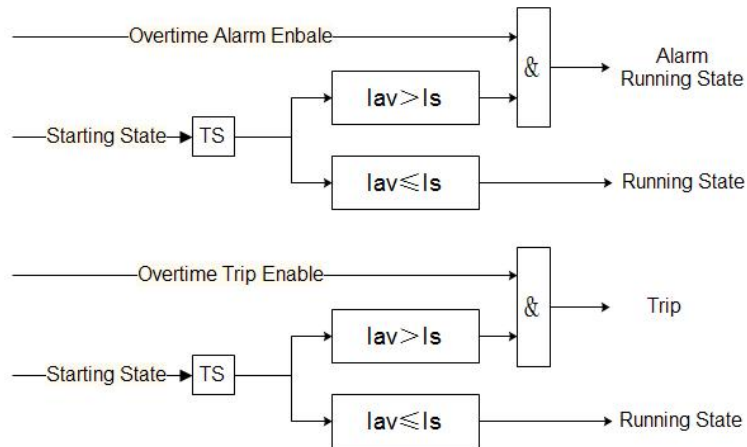

Note:

Iav: Three-phase mean current

Is: Set trip threshold

Ts: Starting time

6.3 Locked-rotor protection

In the process of starting, if the motor shaft is stuck due to excessive load or mechanical reasons, and the fault is not removed in time, the motor will overheat and the insulation will be reduced and the motor will be burned out. The locked-rotor protection is applicable to the motor when such faults occur in the starting stage. When the average current percentage reaches the set threshold, the protector will trip or alarm within the set time in time to avoid the motor burning out.

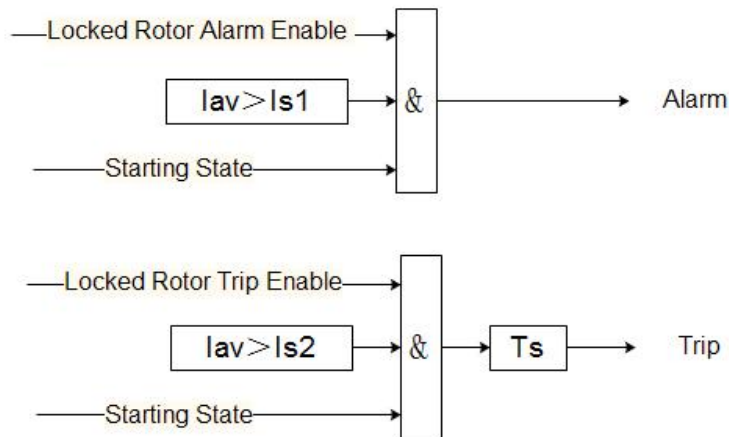

Note:

Iav: Three-phase mean current

Is1: Alarm action threshold

Is2: Tripping threshold

Ts1: Alarm action delay time

Ts2: Delay time of trip action

6.4 Blocking protection

During the operation of the motor, if the motor shaft is stuck due to excessive load or mechanical reasons, and the fault is not removed in time, the motor will be overheated and the insulation will be reduced and the motor will be burned out. The blocking protection is applicable to protect the motor when such faults occur in the running stage. When the average current reaches the set threshold, the protector will trip or alarm within the set time in time to avoid the motor burning out.

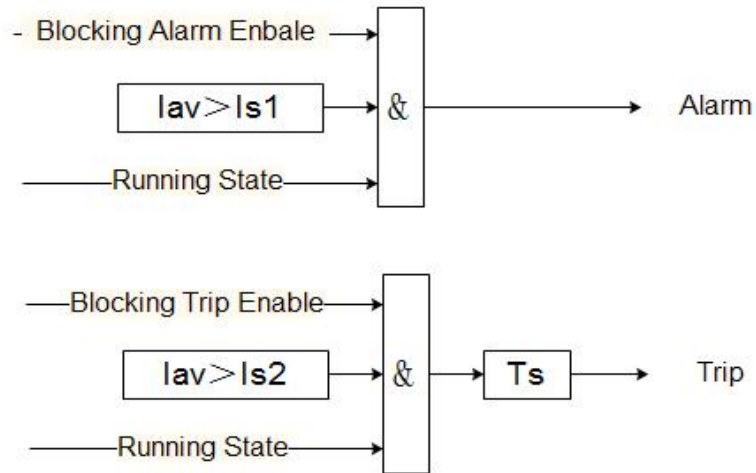

Note:

I_{av} : Three-phase mean current

I_{s1} : Alarm action threshold

I_{s2} : Tripping threshold

T_s : Alarm action delay time

6.5 Underload protection

The protector provides underload protection when the motor is loaded with pumping load. When the average three-phase current is lower than the set value, the protector should trip or alarm within the set time.

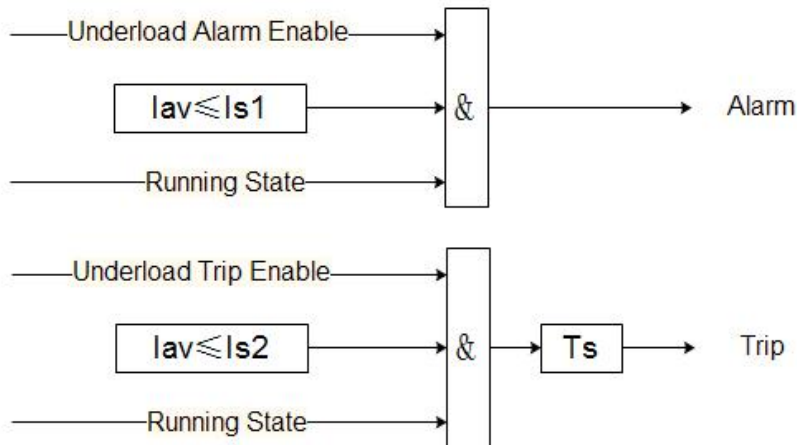

Note:

I_{av} : Three-phase mean current

I_{s1} : Alarm action threshold

I_{s2} : Tripping threshold

T_{s1} : Delay time of alarm action

T_{s2} : Delay time of trip action

6.6 Underpower protection

When the load power is lower than the set action value, the protector will trip or alarm during the set action time.

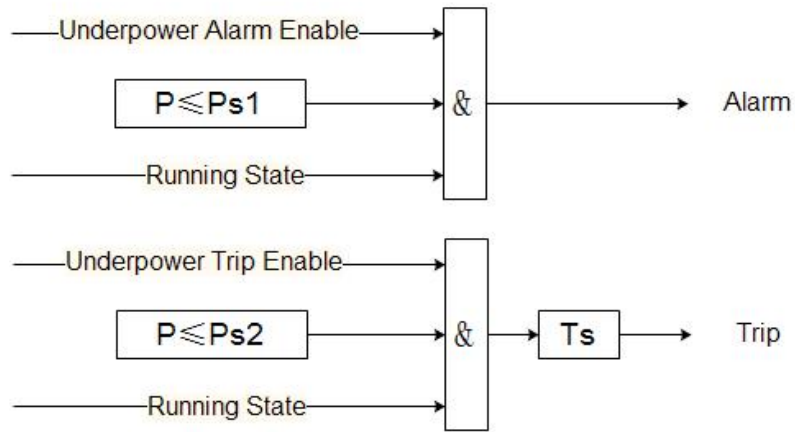

Note:

P: Total active power

Ps1: Alarm action threshold

Ps2: Trip action threshold

Ts1: Delay time of alarm action

Ts2: Delay time of trip action

6.7 Overload protection

In addition to reverse Overload protection, the protector can also provide time-limit overload protection. When the percentage of three-phase average current and rated current is greater than the set value, the protector should trip or alarm within the set time.

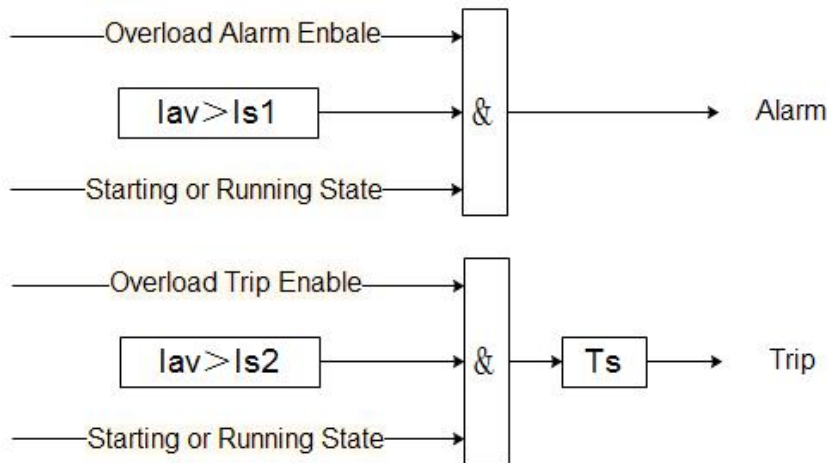

Note:

Iav: Three-phase mean current

Is1: Alarm action threshold

Is2: Tripping threshold

Ts1: Delay time of alarm action

Ts2: Delay time of trip action

6.8 Overpower protection

When the percentage of load power to rated power is greater than the set action value, the protector will trip or

alarm during the set action time.

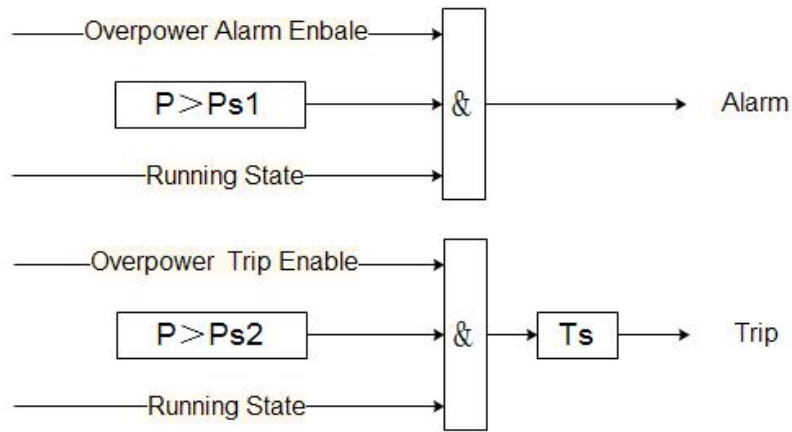

Note:

P: Total active power

Ps1: Alarm action threshold

Ps2: Trip action threshold

Ts1: Delay time of alarm action

Ts2: Delay time of trip action

6.9 Ground fault protection

The protector is protected by the ground current according to the three-phase current vector and the calculation of the ground current. The grounding protection can set the starting shielding time. After the starting shielding time, when the grounding current is greater than the set value, the action logic can choose the breaker or breaker or alarm. When the breaker is chosen, the protector should first switch the breaker and then switch the contactor after 200ms

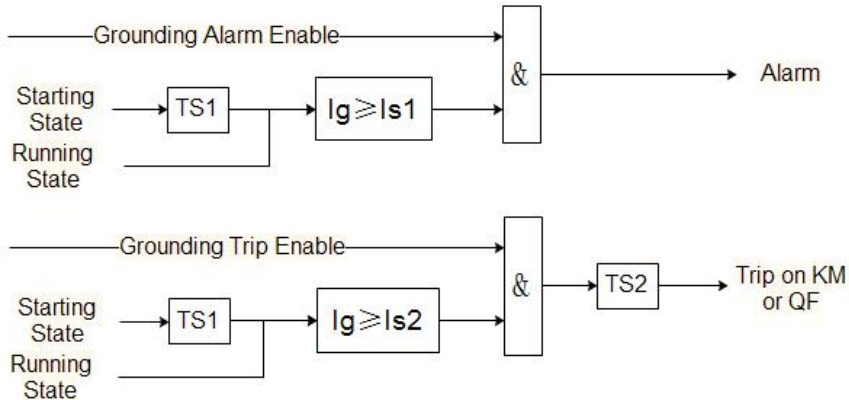

Note:

Ig: Ground current

Is1: Alarm action threshold

Is2: Tripping threshold

Ts1: grounding start shielding time

Ts2: Delay time of alarm action

Ts3: Delay time of trip action

6.10 Leakage protection

Leakage protection should be equipped with leakage current transformer, which can detect the leakage current through the zero-sequence transformer. The leakage protection can set the starting shielding time. After the starting

shielding time, when the leakage current is greater than the set value, the operation logic can choose the breaker or breaker or alarm. When the breaker is chosen, the protector should first switch the breaker and then the breaker after 200ms.

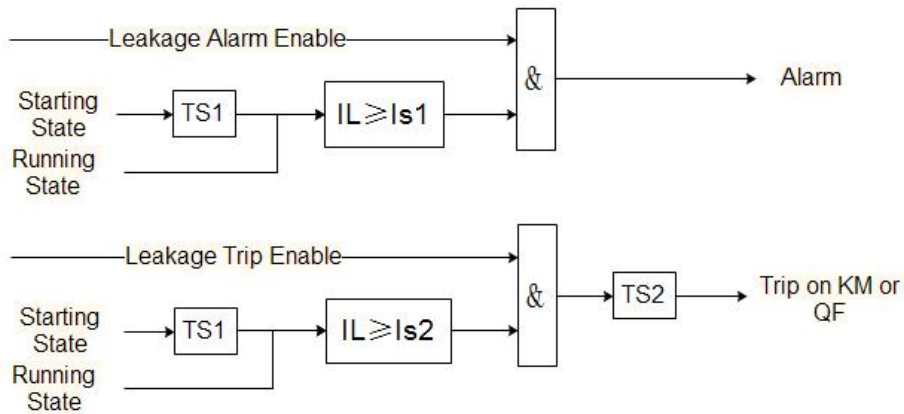

Note:

IL: Leakage current

Is1: Alarm action threshold

Is2: Tripping threshold

Ts1: Shield time for leakage starting

Ts2: Delay time of alarm action

Ts3: Delay time of trip action

6.11 I unbalance protection

The protector calculates the current imbalance degree. When the three-phase current imbalance degree is greater than the set value, it will trip or alarm within the set time. The calculation formula of current imbalance degree is as follows:

$$I_{uf} = \left| \frac{I_{\max(\min)} - I_{av}}{I_{av}} \right| \times 100\%$$

Where, I_{uf} is the current imbalance, I_{\max} is the maximum current, I_{\min} is the minimum current, and I_{av} is the average current.

Note:

I_{uf} : Degree of current imbalance

Is1: Alarm action threshold

Is2: Tripping threshold

Ts1: Delay time of alarm action

Ts2: Delay time of trip action

6.12 Unbalance protection

The protector calculates the voltage unbalance. When the voltage unbalance is greater than the set value, it will trip or alarm within the set time. The calculation formula of voltage imbalance is as follows:

$$U_{uf} = \left| \frac{U_{\max(\min)} - U_{av}}{U_{av}} \right| \times 100\%$$

U_{uf} is the voltage imbalance, U_{\max} is the maximum line voltage, U_{\min} is the minimum line voltage, and U_{av} is the average line voltage.

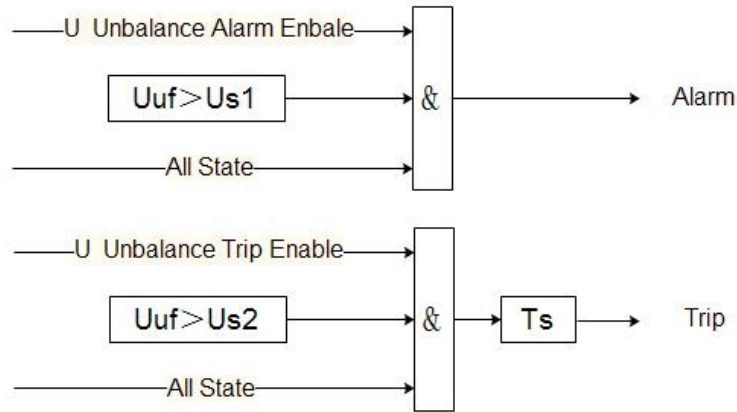

Note:

U_{uf} : Voltage imbalance degree

U_{s1} : Alarm action threshold

U_{s2} : Trip action threshold

T_{s1} : Delay time of alarm action

T_{s2} : Delay time of trip action

6.13 Phase fail protection

When the phase fault runs, it will do great harm to the motor. When the maximum current is greater than 20% rated current and the minimum current is less than 5% rated current, or when the imbalance degree of three-phase current is greater than 30%, the fault protection will trip or alarm within the set time.

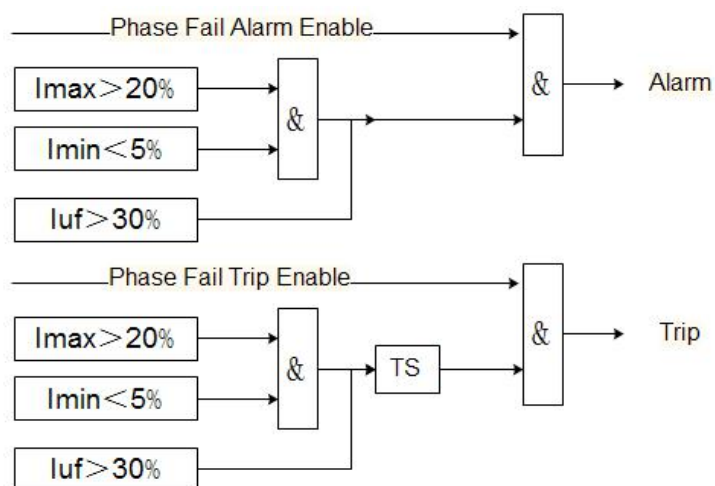

Note:

I_{\max} : Maximum current

I_{\min} : Minimum current

I_{uf} : Degree of current imbalance

Ts1: Delay time of alarm action

Ts2: Delay time of trip action

6.14 Phase sequence protection

When the error of three-phase voltage phase sequence is detected, the protector will trip or alarm within the set time to protect the safety of the motor.

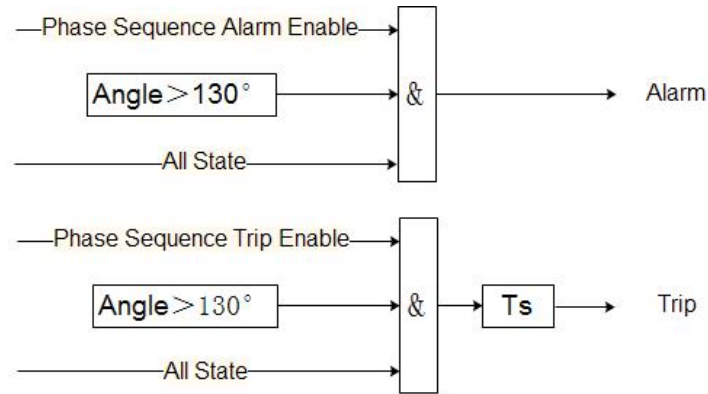

Note:

Angle: The Angle between any two - phase voltage

Ts1: Delay time of alarm action

Ts2: Delay time of trip action

6.15 Overvoltage protection

Excessive voltage will cause damage to the insulation of the motor. When the maximum line voltage of the motor exceeds the set value, the protector will trip or alarm within the set time.

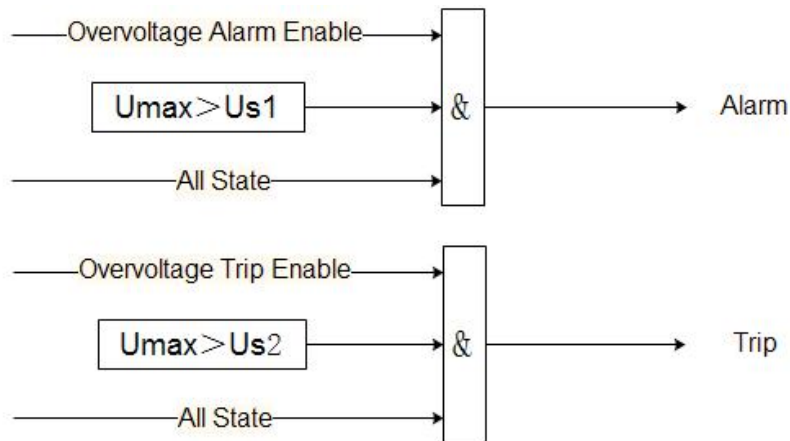

Note:

Umax: Maximum line voltage

Us1: Alarm action threshold

Us2: Trip action threshold

Ts1: Delay time of alarm action

Ts2: Delay time of trip action

6.16 Undervoltage protection

Too low voltage will cause the motor to slow down, or even stop running. When the minimum line voltage of the

motor is lower than the set value, the protector will trip or alarm within the set time.

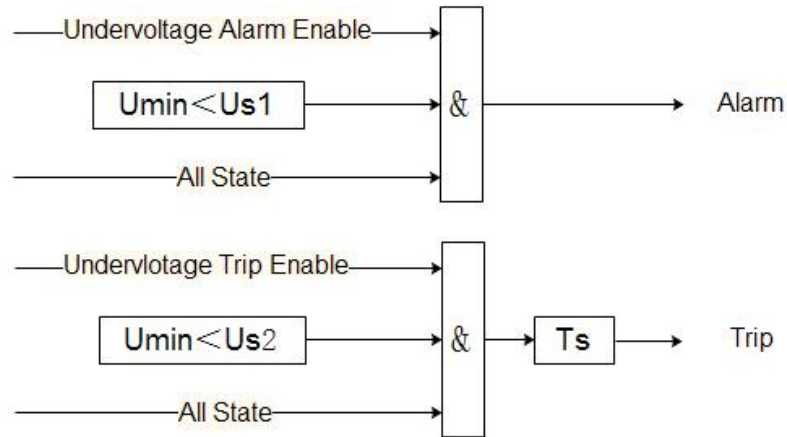

Note:

Umin: Minimum line voltage

Us1: Alarm action threshold

Us2: Trip action threshold

Ts1: Delay time of alarm action

Ts2: Delay time of trip action

6.17 Short circuit protection

When the motor current exceeds the set value, the protector will switch circuit breaker or alarm within the set time. The short circuit protection is divided into two stages: starting and running. The protection parameters of the two stages can be set independently.

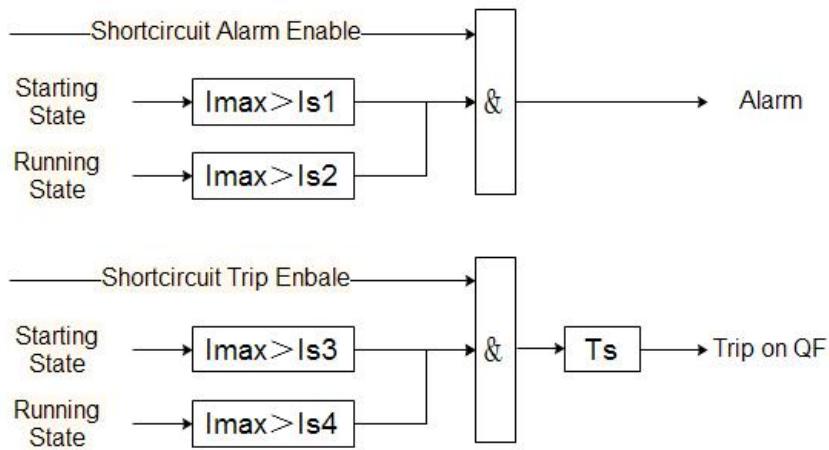

Note:

Imax: Maximum current

Is1: Threshold of short circuit alarm during starting stage

Is2: Threshold of short circuit alarm during operation

Is3: Threshold of short-circuit trip during starting stage

Is4: Threshold of short-circuit trip during operation

Ts1: Delay time of alarm action

Ts2: Delay time of trip action

6.18 Temperature protection

Temperature protection is based on the thermistor resistance embedded in the stator windings or bearings of the motor. According to the type of thermistor selected, the protection logic is different: when the thermistor is PTC, when the detected resistance value is greater than the set value, the protector will trip or alarm within the set time; When the thermistor is NTC, when the detected resistance value is less than the set value, the protector will trip or alarm within the set time

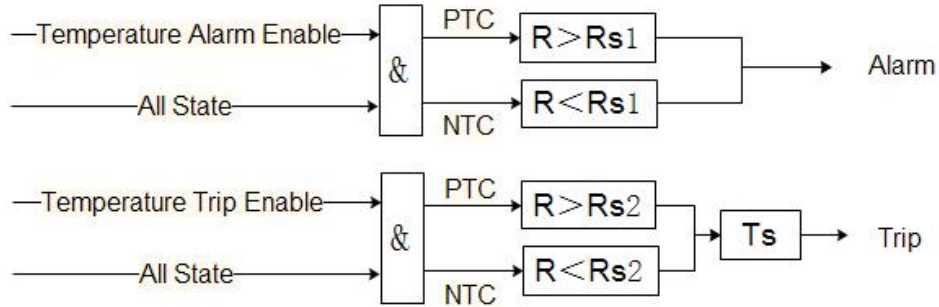

Note:

R: Check the temperature resistance

Rs1: Alarm action temperature resistance value

Rs2: Resistance value of tripping action temperature

Ts1: Delay time of alarm action

Ts2: Delay time of trip action

The temperature protection can be reset manually or automatically. When "Automatic" is selected, the protector will reset automatically after the temperature protection trip when the resistance value is detected to be less than the set return resistance value. When "manual" is selected, after the temperature protection trip, if the resistance value is detected to be less than the set return resistance value, manual manual reset is required, otherwise it will not be allowed to start again.

6.19 External fault

When the input of switch quantity defined as external fault is set as "normally on", the closing signal is taken as the trigger condition of the fault. When the duration of the fault signal is longer than the set tripping/alarm delay time, tripping/alarm will be generated. When the input of switch quantity defined as external fault is set as "normally closed", the disconnect signal is used as the trigger condition of the fault. When the duration of the fault signal is longer than the set trip/alarm delay time, trip/alarm will be generated.

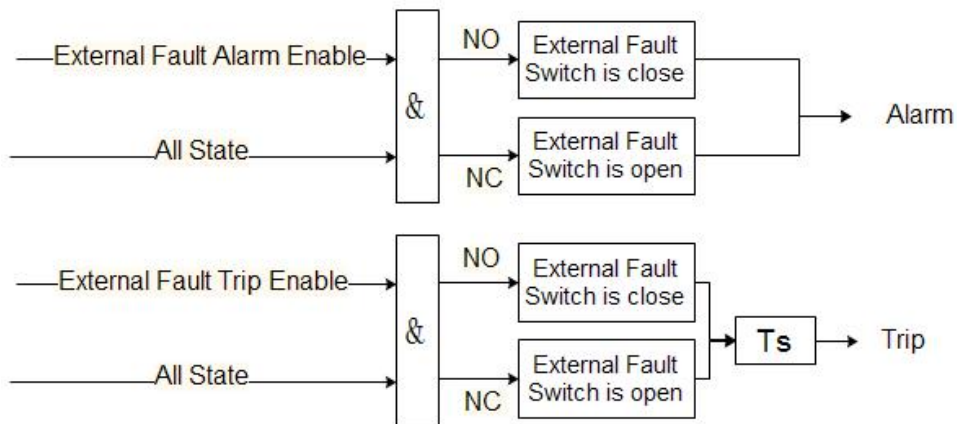

Note:

Ts1: Delay time of alarm action

Ts2: Delay time of trip action

6.20 Overflow protection

When the fault occurs, the current exceeds the breaking current of the contactor, and the contactor will be damaged if the contactor is forcibly disconnected. At this point, the breaker should be broken first, and then disconnect the contactor after the fault current is removed.

If the fault current of the protector is greater than the set overflow current before any other tripping fault action, the breaker should be first switched on, and then the contactor should be switched off after 200ms.

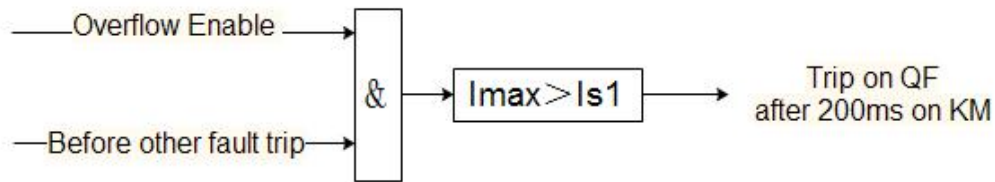

Note:

I_{max} : Maximum current

I_{s1} : Overflow current

6.21 Number of starts protection

The motor is easy to be damaged due to frequent starting and cutting in a short time. When the remaining starting number of the motor is 0 within the set time, the protector sends an alarm signal. If the starting command is issued again at this time, the protector will release and allow to start again after the cooling time.

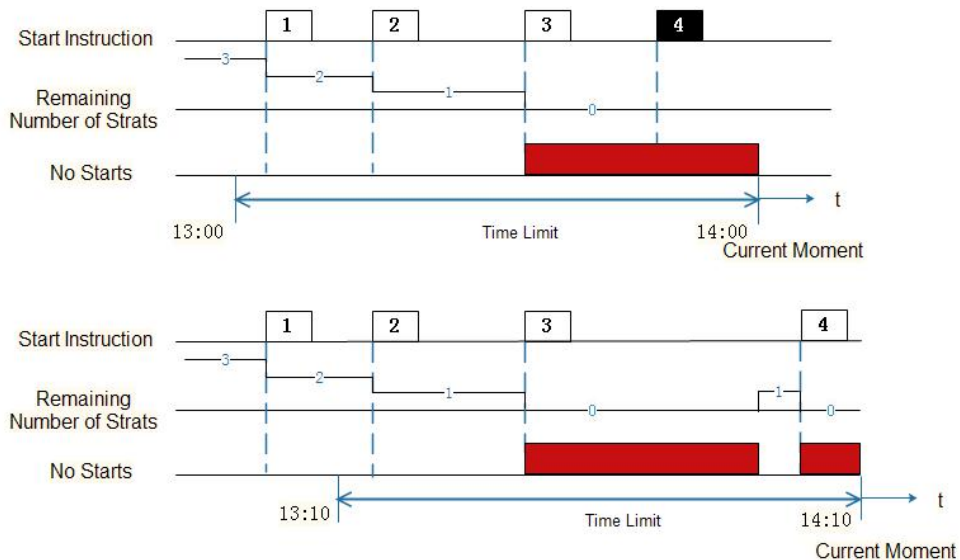

Example: Set the time limit of 1 hour to allow 3 starts.

Figure above: It has been started for 3 times between 13:00 and 14:00, and there is no number of starts at the fourth time, so the fourth time fails.

Figure below: Before the fourth start, the remaining number of starts is restored to 1, so the fourth start is successful.

6.22 Running time alarm

When the accumulated running time of the motor exceeds the set value, the protector will send an alarm signal to remind the staff to overhaul and maintain the motor.

6.23 Fault frequency alarm

When the cumulative number of protection trips exceeds the set value, the protector will send an alarm signal.

7 Function setting and description

7.1 The display module and LED indicator light are shown in Table 10:

Table 10

Serial No.	Name	State	Function Description
1	Start 1 button	press	Manual mode, two-part mode, two-speed mode, star triangle operation start 1 relay
2	Start 2 button	press	Operate and start the 2 relay in manual mode and two-speed mode
3	Stop button	press	Release starting relay
4	Reset button	press	Use in fault state and restore the fault
5	Cancel button	press	Exit menu;Cancel the operation
6	Left keys	press	Upside-down menu;Data is shifted when data is modified
7	Right key	press	Scroll down menu;Modify the data
8	Confirm button	press	Enter the Settings menu and write the modified data
9	Ready LED indicator	bright	The indicator light is always on to indicate that the motor is ready to start
10	Start 1 LED indicator	bright	When this indicator light is on,it indicate that the Start 1 relay output is closed
11	Start 2 LED indicator	bright	When this indicator light is on,it indicate that the Start 2 relay output is closed
12	Stop LED indicator light	bright	The indicator light is always on to indicate that the motor is stopped
13	Starting LED indicator light	bright	The indicator light is always on to indicate that the motor is in starting state
14	Running LED indicator light	bright	The indicator light is always on to indicate that the motor is in running state
15	Alarm LED indicator light	bright	The light indicates an alarm
16	Trip LED indicator light	bright	This indicator light indicates fault trip

7.2 Display module introduction

7.2.1 Data display interface

After the protector is powered on, it enters the data display interface. Press " ⏪ " and " ⏩ " to scroll through the current, voltage, DI/DO state and other information. The specific display content is shown in Figure 12 (the figure below shows the display value in the stopped state)

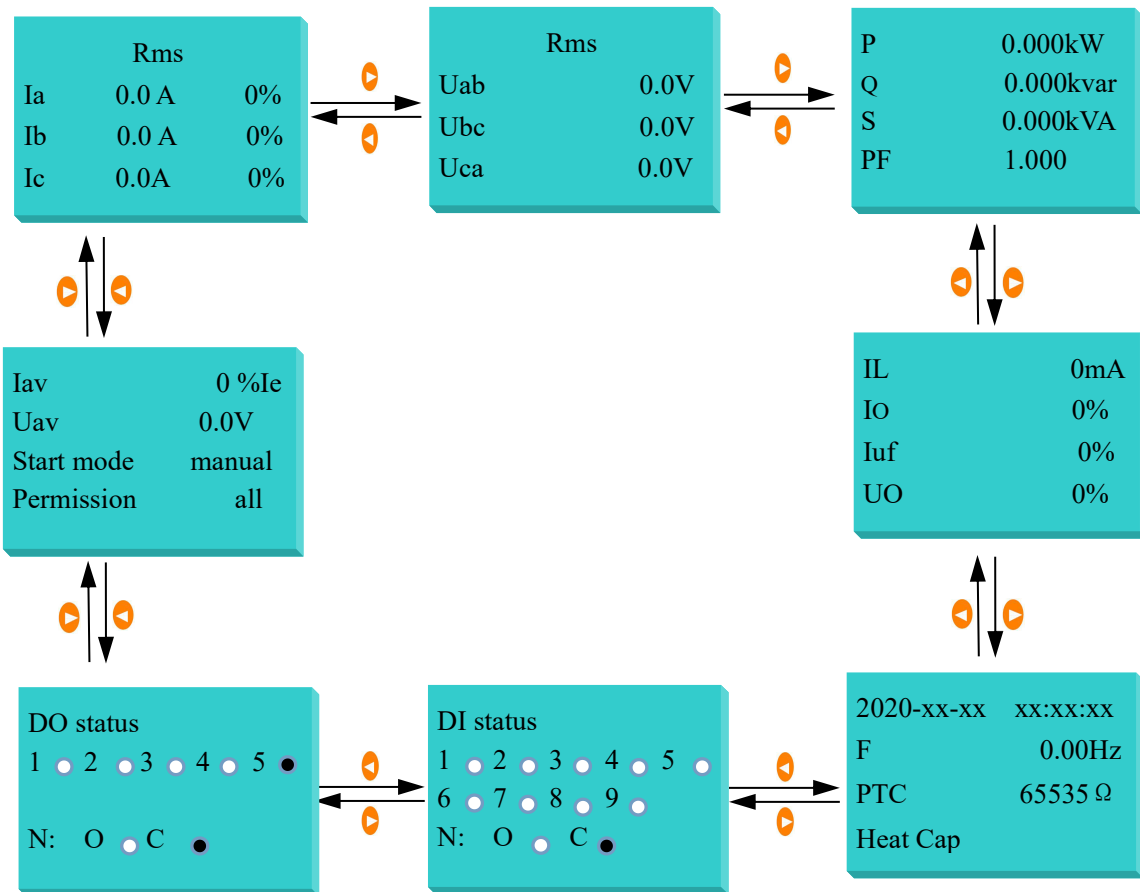

Figure 12 Data display interface

7.2.2 Parameter viewing and setting

When you need to view or set a parameter, first press "OK" to enter the password interface and enter the correct password (default 0001) before entering the main menu. Press the arrow key to move the cursor to the corresponding option, press the "OK" key to enter, and select the corresponding sub-menu for viewing or modification. Figure 13 shows an example of how to modify the control authority:

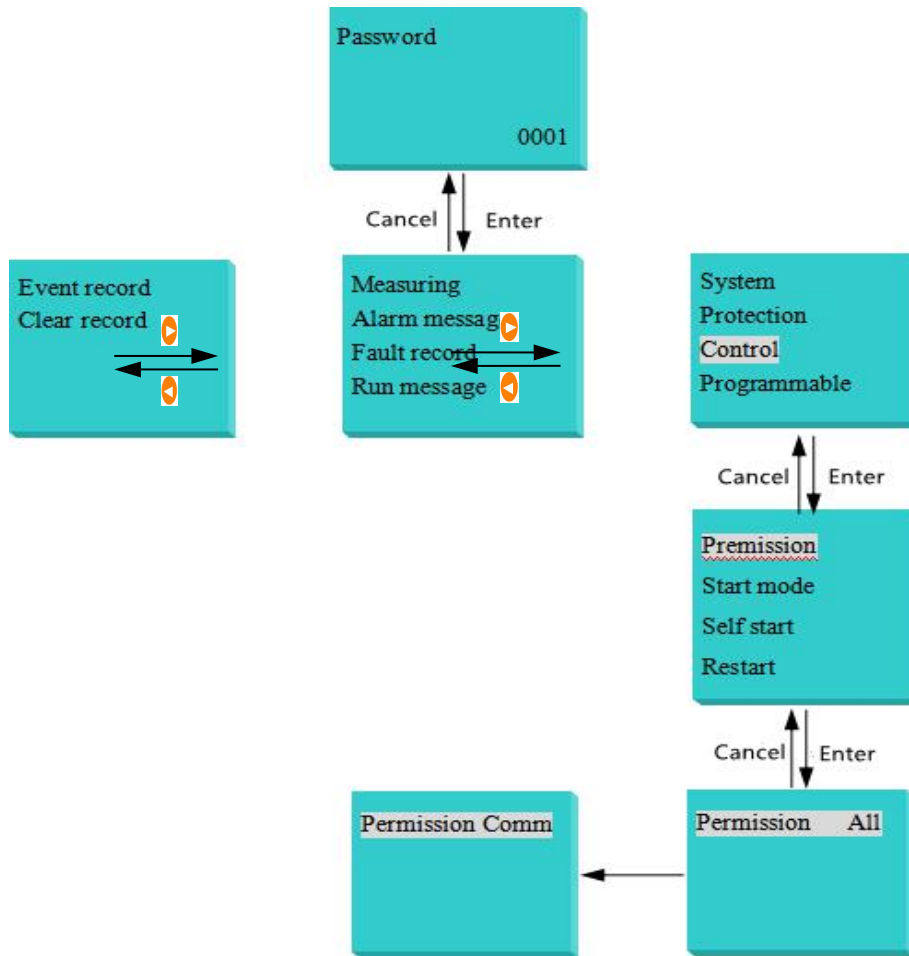

Figure 13 Shows the operation diagram of Ethernet communication parameters

7.3 Menu description

See Table 11 for the ARD2M menu:

Table 11

Serial No.	Main manu	Function	Type	Setting Range	Default value	Unit
1	Measured parameters	Fundamental wave current	—	—	—	A
		Effective current	—	—	—	A
		Fundamental wave voltage	—	—	—	V
		RMS voltage	—	—	—	V
		Voltage phase Angle	—	—	—	
		Other electrical parameters	—	—	—	
2	Alarm information	—	—	—	—	

3	Fault record	—	—	—	—	
4	Running information	Running time of this time	—	—	—	h
		Stop time of this time	—	—	—	h
		Total running time	—	—	—	h
		Total stop time	—	—	—	h
		Start qty	—	—	—	
		Trip qty	—	—	—	
		Maximum start current	—	—	—	A
		Maximum running current	—	—	—	A
5	System parameters	Rated current	—	0.1-1.6	1	A
				1.6-6.3	5	
				6.3~25	25	
				25-100	100	
				63~250	250	
				250~800	800	
		Rated voltage	—	57-1200V	380	V
		Rated power	—	0.12-999kW	—	
		Rated frequency	—	45-70	50	Hz
		Motor type	—	Common motor, increased safety motor	Common motor,	
		High speed motor setting	Rated current	0.1-1.6	1	
				1.6-6.3	5	
				6.3~25	25	
				25-100	100	
				63~250	250	
				250~800	800	
	Rated power	0.12-999kW	—			
Connection mode	—	1P2L、3P3L、3P4L	3P4L			
CT ratio	—	1Aspec.:1-5000 5Aspec.:1-1000	1			
Protection selection	—	Fundamental wave value, full wave value	Fundamental wave value			
Modbus RTU setting	ADD 1	1-247	1			
	Baud rate1	1200、2400、4800、9600、19200、38400	9600	bps		
	Check digit 1	None/2stop/Odd/Even	None			

			ADD 2	1-247	2	
			Baud rate2	2400、4800、9600、19200、38400、Profibus	9600	bps
			Check digit 2	None/2stop/Odd/Even	None	
		Electric leakage protection	——	Off/on	Off	
		Transmitting set	Type 1	Ia、 Ib、 Ic、 Iav、 Uab、 Ubc、 Uca、 Uav、 PTC、 Heat capacity、 P、 F	Iav	
			Full value 1		2 times rated current	
		Language selection	——	Chinese、 English	Chinese	
		backlight	——	1-30s, 0 is normally on	0	
		Liquid crystal contrast	——	0-100	50	%
		password	——	0001-9999	0001	
		Time setting	——	——	——	
		Main interface index	——	1-8	——	
		Software version	——	——	——	
Factory reset	——	yes、 no	——			
6	Protection parameters (low speed)	Fixed time overload	Alarm threshold	100-800%	110%	%
			Trip threshold	100-800%	120%	%
			Trip delay	0.1-600.0s	5.0s	s
			Alarm, trip allowed	Alarm:Allowed/forbidden	Allow	
		Trip:Allowed/forbidden		Allow		
		Inverse time overload	Trip level	1、 2、 3、 5、 10、 15、 20、 25、 30、 35、 40	5	Class
			tE Trip level	2、 3、 4、 5、 6、 8、 10、 12、 15	2	Class
			Start setting	100~800%	120	%
			Reset method	Off/on	Off	
			Cooling time	0-30min	1min	min
			Alarm threshold	1-99%	80%	%
			Starting screen time	0-25.0s	0.5s	s
			Alarm, trip allowed	Alarm:allowed/forbidden	Allow	
		Trip:allowed/forbidden		Allow		
		Underload protection	Alarm threshold	10-99%	70%	%
			Trip threshold	10-99%	50%	%
			Trip delay	0.1-600.0s	5.0s	s

			Alarm, trip allowed	Alarm:allowed/forbidden	Allow	
				Trip:allowed/forbidden	Forbidden	
	phase loss protection		Trip delay	0.1-600.0s	1.0s	s
			Alarm, trip allowed	Alarm:allowed/forbidden	Allow	
				Trip:allowed/forbidden	Allow	
			Current imbalance		Alarm threshold	10~80%
Trip threshold	10~80%	30				%
			Trip delay	0.1~600	5.0	S
Alarm, trip allowed				Alarm:allowed/forbidden	Forbidden	
				Trip:allowed/forbidden	Forbidden	
Locked rotor Protection					Alarm threshold	100-700%
	Trip threshold	100-700%	600%			%
			Trip delay	0.1-600.0s	5.0s	s
	Alarm, trip allowed			Alarm:allowed/forbidden	Allow	
				Trip:allowed/forbidden	Allow	
	Transformer requirements				Yes/No	Yes
Grounding alarm threshold		20-100%	20%			%
	Grounding trip threshold			20-100%	50%	%
Grounding trip delay		0.1-600.0s	0.1s			s
	Trip mode			Circuit breaker / contactor	Circuit breaker	
Grounding starting screen time		0.0-25.0s	0.0s			s
	Current leakage alarm threshold			100-1000mA	200mA	mA
Current leakage trip threshold		100-1000mA	300mA			mA
	Current leakage trip delay			0.1-600.0s	0.5s	s
Trip mode of leakage mode		Circuit breaker / contactor	Circuit breaker			
	Starting screen time			0.0-600s	0.0	s
Alarm, trip allowed		Alarm:allowed/forbidden	Allow			
				Trip:allowed/forbidden	Allow	
Short circuit protection				Alarm threshold	100-800%	Start Alarm400%
	Run Alarm400%					
		Trip threshold	100-800%	Start Trip500%	%	
				Run Trip500%		

			Trip delay	0.1-25.0s	0.1s	s
			Alarm, trip allowed	Alarm:allowed/forbidden	Allow	
				Trip:allowed/forbidden	Allow	
			Overflow protection	Protection threshold	100~800%	600
Alarm, trip allowed	Alarm:allowed/forbidden	Allow				
				Trip: allowed/forbidden	Allow	
Blocking protection				Alarm threshold	100-700%	150%
	Trip threshold	100-700%	250%		%	
		Trip delay	0.1-600.0s	5.0s	s	
	Alarm, trip allowed		Alarm:allowed/forbidden	Allow		
				Trip:allowed/forbidden	Allow	
	Start timeout			action threshold	100%-200%	110%
Timeout time		0.1-600s	10.0s		s	
		Alarm, trip allowed	Alarm:allowed/forbidden	Allow		
					Trip:allowed/forbidden	Allow
	Start times	Timeout quantity			1-10	10
Time range			10-300min	30min	min	
		Alarm, trip allowed	Alarm:allowed/forbidden	Allow		
					Trip: allowed/forbidden	Allow
	overvoltage	Alarm threshold			110-150%	110%
Trip threshold			110-150%	120%	%	
		Trip delay	0.1-600.0s	5.0s	s	
Alarm, trip allowed			Alarm:allowed/forbidden	Allow		
				Trip:allowed/forbidden	Allow	
Under voltage				Alarm threshold	50-90%	90%
	Trip threshold	50-90%	80%		%	
		Trip delay	0.1-600.0s	5.0s	s	
	Alarm, trip allowed		Alarm:allowed/forbidden	Forbidden		
				Trip:allowed/forbidden	Forbidden	
	Voltage unbalance			Alarm threshold	10-99%	15%
Trip threshold		10-99%	20%		%	
		Trip delay	0.1-600.0s	0.5s	s	
Alarm, trip allowed			Alarm:allowed/forbidden	Forbidden		
				Trip:allowed/forbidden	Forbidden	
Phase sequence				Trip delay	0.1-25.0s	1.0s
	Alarm:allowed/forbid den	Forbidden	Alarm:allo wed/forbi dden			
		Trip:allowed/forbidde	Forbidden	Trip:allow		

			n		ed/forbidden	
		Over power	Alarm threshold	100-700%	150%	%
			Trip threshold	100-700%	250%	%
			Trip delay	0.1-600.0s	5.0s	s
			Alarm, trip allowed	Alarm:allowed/forbidden	Forbidden	
		Trip:allowed/forbidden		Forbidden		
		under-power	Alarm threshold	0-100%	80%	%
			Trip threshold	0-100%	50%	%
			Trip delay	0.1-600.0s	5.0s	s
			Alarm, trip allowed	Alarm:allowed/forbidden	Forbidden	
		Trip:allowed/forbidden		Forbidden		
		temperature protection	NTC/PTC	NTC/PTC	PTC	
			Alarm threshold	100-30000 Ω	1600 Ω	Ω
			Trip threshold	100-30000 Ω	3600 Ω	Ω
			Trip delay	0.1-600.0s	5.0s	s
			Reset method	Manual and automatic	automatic	
			Return resistance value	100-30000 Ω	1500 Ω	
			Alarm, trip allowed	Alarm:allowed/forbidden	Forbidden	
		Trip:allowed/forbidden		Forbidden		
		external fault	Trip delay	0.1-600.0s	5.0s	s
			Alarm, trip allowed	Alarm:allowed/forbidden	Forbidden	
				Trip: allowed/forbidden	Forbidden	
		Run timeout	Alarm threshold		10000h	h
			Alarm allowed	allowed/forbidden	Forbidden	
		Fault times	Alarm threshold		1000 times	times
			Alarm allowed	allowed/forbidden	Forbidden	
	Protecting parameters (high speed)	Refer to the low speed protection setting sheet				
7	Control parameters	Control access	Control access	Display unit、 localization、 communication、 remote、 1 in 3、 1 in 2、 all control	All control	
		Start method	Start mode	Protection mode, manual mode, two-step mode, two-speed mode, star triangle, auto-step-down	Protected mode	
				start1 delay	0.1-600	3.0
		Self start	Self start mode	recover/start	start	
			Self start delay	0.1~600	5.0	S
Self start control	On/off		Off			

8	Programmable Settings	Voltage loss restart	Recovery voltage	70-95%	80	%
			Voltage drop	50-90%	50	%
			Sway electric time	0.5-300.0	5.0	S
			Restart delay	1.0-60.0s	30.0	S
			Immediate restart time	0.1-10.0s	0.5	S
			Restart function	on/off	Off	
		DI set	DI1 type	Normally on/normally off	Normally on	
			DI1	1-Ordinary DI, 2-starting 1(in situ), 3-starting 1(remote), 4-starting 2(in situ), 5-starting 2(remote), 6-parking (in situ), 7-parking (remote), 8-reset, 9-emergency stop, 10-external fault, 11-single point 1 (in situ) start-stop, 12-single point 1 (remote) start-stop, 13-single point 2 (in situ) start-stop, 14-single point 2 (remote) start-stop, 15-single point 1 start/stop, 16-single point 2 start/stop, 17-control over 1, 18-control over 2	Stop	
			DI2	Ditto	Start1	
			DI3	Ditto	Start2	
			DI4	Ditto	Urgent Stop	
			DI5	Ditto	Reset	
			DI6	Ditto	control right 1	
DI7	Ditto		control right 2			
DI8	Ditto	External fault				
DO setting	DO1 type	Normally on/normally off	Normally on			
	DO1 Definition	0-No input, 1-star 1, 2-start 2,3-start3, 4-parking,5-starting jumped	Start1			

				<p>contactor,6-circuit breakers,7-fault Alarm output,8-tripping fault output,9-the output state stopped,10-the starting state output,11-the output operation state,12-the communication control output,13-the output device self-checking,14-the device output power,15-nowhere electric process output chain,16-electric reset signal output,17-protected mode have nowhere electricity output 1,18-protected mode electricity output 2,19-logic diagram output 1,20-logic diagram output 2, 21-logic diagram output 3, 22-30 corresponding DI1-9 control the DO output</p>				
			Pulse time	0.3-25.0s	0.0s	s		
			DO2	Ditto	start2			
			DO3	Ditto	alarm			
			DO4	Ditto	trip			
			DO5	Ditto	trip			
		Logic diagram setting	inputA	Input A definition	DI1			
				Input A logic			Positive logic/Reserve logic	Positive logic
				Input A delay			0.0-60.0s	0.0s
			inputB	Input B	Ditto	Off		
				Close;DI1-19;DO1 - DO6;Starting 1;Starting 2;Starting 3;Stop,Emergency shutdown;Stop state;Starting state;Running state;Alarm status;Trip status;Trip type (choose one of 22 fault types);Alarm types (choose one of 24 Alarm types))				

				definition			
				Input B logic	Positive logic/Reserve logic	Positive logic	
				Input B delay	0.0-60.0s	0.0s	
		inputC		Input C definition	Ditto	Off	
				Input C logic	Positive logic/Reserve logic	Positive logic	
				Input C delay	0.0-60.0s	0.0s	
		inputD		Input D definition	Ditto	Off	
				Input D logic	Positive logic/Reserve logic	Positive logic	
				Input D delay	0.0-60.0s	0.0s	
		inputE		Input E definition	Ditto	Off	
				Input E logic	Positive logic/Reserve logic	Positive logic	
				Input E delay	0.0-60.0s	0.0s	
			Logic diagram1	off、 A、 A*B、 A+B、 A*B*C、 (A+B)*C、 (A*B)+C、 A+B+C、 A*B*C*D、 (A+B)*C*D、 (A*B+C)*D、 (A+B+C)*D、 A*B*C+D、 (A+B)*C+D、 A*B+C+D、 A+B+C+D、 A*B*C*D*E、 (A+B)*C*D*E、 (A*B+C)*D*E、 (A+B+C)*D*E、 (A*B*C+D)*E、 ((A+B)*C+D)*E、 (A*B+C+D)*E、 (A+B+C+D)*E、 A*B*C*D+E、 (A+B)*C*D+E、 (A*B+C)*D+E、 (A+B+C)*D+E、 A*B*C+D+E、 (A+B)*C+D+E、 A*B+C+D+E、 A+B+C+D+E	A		

			Logic diagram 2	Ditto	A	
			Logic diagram 3	Ditto	A	
		Test	DO1	Off/on	Off	
			DO2	Off/on	Off	
			DO3	Off/on	Off	
			DO4	Off/on	Off	
		DO5	Off/on	Off		
11	Event log	DI displace records				
		Start recording				
		Stop record				
		Restart record				
12	Clear record	Clear record password		0000-9999	0001	

8 Communication Settings and instructions

8.1 Modbus RTU Communication Protocol Overview

Electrical interface: RS485 half duplex

Baud: 1200/2400/4800/9600/19200/38400

Address: Consists of one byte (8-bit binary), 0 to 255 in decimal, only 1 to 247 in the system, the rest reserved

Error detection: CRC

Data format:

Address code	Function code	Data area	CRC check
--------------	---------------	-----------	-----------

Data length:

1 byte	1 byte	N byte	2 byte
--------	--------	--------	--------

Each byte bit: 1 bit start, 8 bit data (least significant bit sent first), no parity, 1 bit stop

MODBUS function code supported by ARD2M:

01 (0x01) Function code: Read coil state (relay output DO, address 0 corresponds to DO1)

02 (0x02) Function code: Read switch input state (DI, address 0 corresponds to DI1)

03/04 (0x03, 0x04) Function code: read hold register

05 (0x05) Function code: write coil state (control relay output DO, address 0 corresponds to DO1)

06 (0x06) Function code: Write a single register

16 (0x10) function code: Write multiple registers

Note: The operation control bit and output control bit are written in 16 function codes.

Communications applications

The examples in this section use the following tabular format (in hexadecimal data) whenever possible

Addr	Fun	Data start	Data	CRC16
------	-----	------------	------	-------

		reg Hi	reg Lo	reg Hi	reg Lo	Lo	Hi
01H	03H	00H	00H	00H	06H	C5H	C8H
Add	Function code	Data starting address		Data read qty		Cyclic redundancy check code	

Read the data

Example 1: Read register using the 01 function: read the OUTPUT status of DO1-DO5 relay of the 01 ARD2M protector

Check data frame	01 01 00 00 00 05 FC 09
Return data frame	01 01 01 10 50 44

Example 2: Register read using the 02 function: read the di1-DI5 switch input status of the 01 ARD2M protector

Check data frame	01 02 00 00 00 05 B8 09
Return data frame	01 02 01 10 A0 44

Example 3: Register read using the 03 or 04 function: read 01 ARD2M and read 3 data from address 400

Check data frame	01 03 01 90 00 03 04 1A
Return data frame	01 03 06 00 00 00 00 00 0E D1

Write the data

Example 4: Use the 05 function to write registers

Close DO1 relay no. 01 ARD2M:

Check data frame	01 05 00 00 FF 00 8C 3A
Return data frame	01 05 00 00 FF 00 8C 3A

Disconnect DO1 relay of No. 01 ARD2M:

Check data frame	01 05 00 00 00 00 CD CA
Return data frame	01 05 00 00 00 00 CD CA

Example 5: Write register using 06 function: output DO2 of 01 ARD3M. The indicating register address of switch input/output state is 022DH, bit 022DH-9 corresponds to Di1-10, bit 10 corresponds to DO6, and bit 11-15 corresponds to DO1-5.

Check data frame	01 06 02 2D 10 00 15BB
Return data frame	01 06 02 2D 10 00 15 BB

Example 6: Write register with 16 function: output DO2 of 01 ARD2M. The indicating register address of switch input/output state is 022DH, bit 022DH-9 corresponds to Di1-10, bit 10 corresponds to DO6, and bit 11-15 corresponds to DO1-5.

Check data frame	01 10 02 2D 00 01 02 10 00 8E 2D
Return data frame	01 10 02 2D 00 01 90 78

The detailed MODBUS address of ARD2M is shown in table 12

Table 12

Classification	Addr.	Parameter	Read write attrib	Value range	Type
----------------	-------	-----------	-------------------	-------------	------

			ute		
Measure parameters	400	A Phase effective value current percentage	R	0-1200%	word
	401	B Phase effective value current percentage	R		word
	402	C Phase effective value current percentage	R		word
	403	Average effective value current percentage	R		word
	404	Maximum RMS current Percentage	R		word
	405	A Phase fundamental current percentage	R		word
	406	B Phase fundamental current percentage	R		word
	407	C Phase fundamental current percentage	R		word
	408	Average fundamental current percentage	R		word
	409	Maximum fundamental current percentage	R		word
	410	Ground current percent	R		word
	411	positive sequence current percentage	R		word
	412	Negative sequence current percentage	R	word	
	413	A Phase fundamental current	R	0-65535/Current scaling factor is the actual value	word
	414	B Phase fundamental current	R		word
	415	C Phase fundamental current	R		word
	416	Uab Fundamental line voltage	R	0~1999.9V	word
	417	Ubc Fundamental line voltage	R	0~1999.9V	word
	418	Uca Fundamental line voltage	R	0~1999.9V	
	419	leakage current	R	30-3000mA	
	420	A Phase effective current	R	0-65535/current scaling factor is the actual value	word
421	B Phase effective current	R	word		

422	C Phase effective current	R		word
423	Uab RMS line voltage	R	0~1999.9V	word
424	Ubc RMS line voltage	R	0~1999.9V	word
425	Uca RMS line voltage	R	0~1999.9V	word
426	frequency	R	15.00-75.00Hz	word
427	Degree of current imbalance	R	0-100%	
428	Percentage of cumulative heat capacity	R	0-100%	word
429	Temperature resistance	R	0-65535 Ω	word
430	Zero sequence voltage percent	R	0-999%	High byte word
431	Percentage of positive sequence voltage	R	0-999%	Low byte word
432	Percentage of Negative sequence voltage	R	0-999%	signed short int
433	Voltage imbalance	R	0-999%	
434	AB Phase voltage phase Angle difference	R	0-359.9°	word
435	BC Phase voltage phase Angle difference	R	0-359.9°	
436	CA Phase voltage phase Angle difference	R	0-359.9°	
437-439	Reserved	R		
440	fundamental wave Total active power	R	32 bit signed number, High byte before, low byte after Unit:W	High byte word
441		R		Low Byte word
442	fundamental wave Total reactive power	R	32 bit signed number, High byte before, low byte after Unit:var	High byte word
443		R		Low byte word
444	fundamental wave Total apparent power	R	32 bit unsigned number, High byte before, low byte after Unit:VA	High byte word
445		R		Low byte word
446	Fundamental wave total active energy	R	32 bit unsigned number, High byte before, low byte	High byte word

	447		R	after Unit:Wh	Low byte word
	448	Fundamental wave total reactive energy	R	32 bit unsigned number, High byte before, low byte after Unit:varh	High byte word
	449		R		Low byte word
	450	fundamental wave A phase active	R	32 bit signed number, High byte before, low byte after Unit:W	High byte word
	451		R		Low byte word
	452	fundamental wave B phase active	R	32 bit signed number, High byte before, low byte after Unit:W	High byte word
	453		R		Low byte word
	454	fundamental wave C phase active	R	32 bit signed number, High byte before, low byte after Unit:W	High byte word
	455		R		Low byte word
	456	Fundamental wave A phase reactive	R	32 bit signed number, High byte before, low byte after Unit:var	High byte word
	457		R		Low byte word
	458	Fundamental wave B phase reactive	R	32 bit signed number, High byte before, low byte after Unit:var	High byte word
	459		R		Low byte word
	460	Fundamental wave C phase reactive	R	32 bit signed number, High byte before, low byte after Unit:var	High byte word
	461		R		Low byte word
	462	fundamental wave A phase apparent	R	32 bit unsigned number, High byte before, low byte after Unit:VA	High byte word
	463		R		Low byte word
	464	fundamental wave B phase apparent	R	32 bit unsigned number, High byte before, low byte after Unit:VA	High byte word
	465		R		Low byte word
	466	fundamental wave C phase apparent	R	32 bit unsigned number, High byte before, low byte after Unit:VA	High byte word
	467		R		Low byte word
	468- 495	Retain	R		

	496	Fundamental wave power factor		-1.000~1.000	word
	497	Fundamental wave A phase power factor		-1.000~1.000	word
	498	Fundamental wave B phase power factor		-1.000~1.000	word
	499	Fundamental wave C phase power factor		-1.000~1.000	word
	500-503	Retain	R		
	504	Year,month	R/W	High byte:00-99,Low byte:0-12	word
	505	Day,hour	R/W	High byte:0-31,,Low byte:0-23	word
	506	Minute,second	R/W	High byte:0-59,,Low byte:0-59	word
	507	reserve	R	0-65535	word
	508	Motor running time by now	R	0-65535	word
	509	Total motor stopping times	R	0-65535	word
	510	Total running times	R	0-65535	word
	511-549	Retain	R		
Motor running information	550	Total starting times	R	0-65535 Hour	word
	551	Total tripping times	R	0-65535 Hour	word
	552	reserve	R	0-65535 Hour	word
	553	Motor running time by now	R	0-65535 Hour	word
	554	Total motor stopping times	R	0-65535	word
	555	Total running times	R	0-65535	word
	556	DI STATE	R	Bit0-bit8 To Switch Input DI1-DI9	word
	557	DO STATE	R/W	Bit0 relay 1, Bit1 relay 2, Bit2 relay 3, Bit3 relay 4, Bit4 relay 5, Bit5 relay 6	
	558	DI/DO TYPE	R	0-DC type; 1-AC type	
	559	MOTOR STATE	R	bit0 readiness; bit1 Stopping; bit2 start; bit3 operation; bit4 alarm; bit5 tripping; bit7 0- Low speed 1- High speed	word
	560	Trip Breakdown fault		Bit0 reverse time limit	word

		indication 1		<p>overload tripping; Bit1 grounding tripping; Bit2 underload tripping Bit3 disconnection; Bit4 undervoltage release; Bit5 overvoltage release; Bit6 blocking and tripping; Bit7 blocking tripping; Bit8 current imbalance tripping; Bit9 PTC temperature tripping; Bit10 external failure tripping; Bit11 start timeout release; Bit12 power tripping; Bit13 underpower tripping; Bit14 phase sequence tripping; Bit15 short circuit tripping. (0- No tripping, (1)</p>	
	561	Trip Breakdown fault indication 2	R	<p>Bit0 fixed time limit overload tripping; Bit1 voltage unbalanced tripping; Bit2 overflow protection tripping; Bit3 starting times tripping.</p>	word
	562	Alarm fault indication 1	R	<p>Bit0 anti-time overload alarm; Bit1 ground alarm; Bit2 underload alarm; Bit3 fault phase alarm; Bit4 undervoltage alarm; Bit5 overvoltage alarm; Bit6 blocking alarm; Bit7 blocking alarm; Bit8 current imbalance alarm; Bit9 PTC temperature alarm; Bit10 external fault alarm; Bit11 start timeout alarm; Bit12 power alarm; Bit13 underpower alarm; Bit14 phase sequence alarm; Bit15 short circuit alarm. (0- No alarm, 1- Alarm)</p>	word
	563	Alarm fault indication	R	Bit0 fixed time limit overload	word

	2		alarm; Bit1 voltage imbalance alarm; Bit2 overflow protection alarm; Bit3 starting times alarm; Bit4 running time alarm; Bit5 fault times alarm	
564	Overload remaining cooling time	R	0-30min	word
565	Maximum starting current by now	R	0-65535	word
566	Maximum Historical starting current	R	0-65535	word
567	Maximum current in operation by now	R	0-65535	word
568	Maximum Historical operation current	R	0-65535	word
569	Latest Fault Record Communication Address	R	2100、2150、2200、2250、 2300、2350、2400、2450	word
570	Latest DI Change Record Communication Address	R	1100、1108、1116、1124、 1132、1140、1148、1156	word
571	Latest Starting Record Communication Address	R	1300、1308、1316、1324、 1332、1340、1348、1356	word
572	Latest Stopping Record Communication Address	R	1500、1508、1516、1524、 1532、1540、1548、1556	word
573	Latest Restart Record Communication Address	R	1700、1708、1716、1724、 1732、1740、1748、1756	word
574	Latest Parameter setting Communication Address	R	1900、1906、1912、1918、 1924、1930、1936、1942	word
575	Latest installation to record correspondence communication address	R	2020、2024、2028、2032、 2036、2040、2044、2048	word
576	Latest device power off record communication address	R	2052、2056、2060、2064、 2068、2072、2076、2080	word
577	Current recorded times of power on	R	0-60000	word
578	Current recorded times	R	0-60000	word

		of power off			
	579	Waiting time for next start	R	0-30min	word
	580	Current Motor Control Authority	R	0-panel ;1-native ;2-communication ;3-remote ;4-stop ;5-All	word
	581-596	Retain	R		word
Clear the record	597	Energy clear	W	Write data 0xa5b5	word
	598	Clear motor operation information	W	Write data 0xa5b5	word
	599	Event record clear	W	Write data 0xa5b5	word
System parameter	600	Current	R	1.6、6.3、25.0、100.0、250.0、800.0、1.0、5.0	word
	601	Current proportional factor	R	1、10、100	
	602	Operational control bits	R/W	1-Stop、2-Start 1、3- Start 2、4-Emergency stop、5-resei	word
	603	Restore factory setting	R/W	Write data 0xFFFF	word
	604	Input Mark of Residual Current Transformer	R/W	0 not input, 1 input	word
	605	Base Wave Switch	R/W	0 Rms, 1 Fundament	word
	606	Motor type	R/W	0 Common motor, 1 Increased safety motor	word
	607	CT Ratio	R/W	1A:1-5000 5A:1-1000 other specifications can not set CT ratio	word
	608	Rated Frequency	R/W	45-70Hz	word
	609	Motor rated current	R/W	1A:0.1-1.6A 5A:1.6A-6.3A 25A:6.3-25.0A 100A:25.0-100.0A 250A:63.0-250.0A 800A:250.0-800.0A	word
	610	Motor rated voltage	R/W	57-1200	word
	611	Motor rated Power	R/W	High byte	word
	612		R/W	Low byte	word
	613	Wiring	R/W	0:1P,1:3P4L, 2:3P3L	word
	614	Back light	R/W	1-30s, 0:Normally on	word
	615	Liquid crystal contrast	R/W	0~100	word
	616	Main interface index	R/W	1-7(0-20 can write)	word
617	Language	R/W	0-Chinese, 1-English	word	
618	Current mask value	R/W	0-30	word	
619	Password	R/W	0000-9999		

	620	Analog output setting	R/W	Type:0-Ia,1-Ib,2-Ic,3-Iav,4-Uab,5-Ubc,6-Uca,7-Uav,8-PTC,9-Heat capacity,10-P,11-F	word
	621	Full value	R/W	2 times rated current	word
	622		R/W		
	623-645	Retain	R		word
	646	LCD version	R		word
	647	LCD NO.	R		word
	648	Main body version	R		word
	649	Main body NO.	R		word
Low speed protection	650	Trip allowed/forbidden 1	R/W	Bit0 reverse time limit overload tripping; Bit1 grounding tripping; Bit2 underload tripping Bit3 disconnection; Bit4 undervoltage release; Bit5 overvoltage release; Bit6 blocking and tripping; Bit7 blocking tripping; Bit8 current imbalance tripping; Bit9 PTC temperature tripping; Bit10 external failure tripping; Bit11 start timeout release; Bit12 power tripping; Bit13 underpower tripping; Bit14 phase sequence tripping; Bit15 short circuit tripping. (0-No tripping, 1-trippng)	word
	651	Trip allowed/forbidden 2	R/W	Bit0 fixed time limit overload tripping; Bit1 voltage unbalanced tripping; Bit2 overflow protection tripping; Bit3 starting times tripping.	word
	652	Alarm allowed/forbidden 1	R/W	Bit0 anti-time overload alarm; Bit1 ground alarm; Bit2 underload alarm; Bit3 fault phase alarm; Bit4 undervoltage alarm; Bit5	word

			overvoltage alarm; Bit6 blocking alarm; Bit7 blocking alarm; Bit8 current imbalance alarm; Bit9 PTC temperature alarm; Bit10 external fault alarm; Bit11 start timeout alarm; Bit12 power alarm; Bit13 underpower alarm; Bit14 phase sequence alarm; Bit15 short circuit alarm. (0- No alarm, 1- Alarm)	
653	Alarm allowed/forbidden 2	R/W	Bit0 fixed time limit overload alarm; Bit1 voltage imbalance alarm; Bit2 overflow protection alarm; Bit3 starting times alarm; Bit4 running time alarm; Bit5 fault times alarm	word
654	Trip level	R/W	1、2、3、5、10、15、20、 25、30、35、40	word
655	tE Trip level	R/W	2、3、4、5、6、8、10、12、 15	word
656	Start setting	R/W	100-800%	word
657	Reset method	R/W	0-Off; 1-On	word
658	Overload cooling time	R/W	0-30min	word
659	Overload alarm threshold	R/W	1-99%	word
660	Overload starting protection screen time	R/W	0-25.0	word
661	Ground fault alarm threshold	R/W	20%-100%	
662	Ground fault trip threshold	R/W	20%-100%	
663	Ground fault protection delay	R/W	0.1~600.0s	word
664	Trip mode	R/W	Bit(0- circuit breaker 1- contactor)	word
665	Ground fault starting screen time	R/W	0-25.0	word
666	Leakage alarm threshold	R/W	(100~1000)mA	word
667	Leakage trip threshold	R/W	(100~1000)mA	word

668	Leakage trip delay	R/W	0.1~600.0s	
669	Leakage action choice	R/W	Bit0:Action choice(0-Circuit breaker 1-contactor)	
670	Leakage fault starting screen time	R/W	0-25.0	
671	Under power alarm threshold	R/W	10~99%	
672	Under power trip threshold	R/W	10~99%	
673	Under power trip delay	R/W	0.1~600.0s	word
674	Phase loss trip delay	R/W	0.1~600.0s	word
675	Under voltage alarm threshold	R/W	50~90%	
676	Under voltage trip threshold	R/W	50~90%	word
677	Under voltage trip delay	R/W	0.1~600.0s	word
678	Over voltage alarm threshold	R/W	110~150%	
679	Over voltage trip threshold	R/W	110~150%	
680	Over voltage trip delay	R/W	0.1~600.0s	word
681	Locked-rotor alarm threshold	R/W	100~700%	
682	Locked-rotor trip threshold	R/W	100~700%	
683	Locked-rotor trip delay	R/W	0.1~600.0s	word
684	Blocking alarm threshold	R/W	100~700%	
685	Blocking trip threshold	R/W	100~700%	
686	Blocking trip delay	R/W	0.1~600.0s	word
687	Current unbalance alarm threshold	R/W	10~99%	
688	Current unbalance trip threshold	R/W	10~99%	
689	Current unbalance trip delay	R/W	0.1~600.0s	word
690	NTC /PTC	R/W	0 NTC, 1PTC	
691	Temperature alarm threshold	R/W	100~30000	
692	Temperature trip threshold	R/W	100~30000	word
693	Temperature trip delay	R/W	0.1~600.0s	
694	Temperature fault reset mode	R/W	0-Manual; 1-Automatic	
695	Temperature return resistance	R/W	0-Off,Can be set between 100-30000	
696	External fault trip delay	R/W	0.1~600.0s	word
697	Start timeout trip threshold	R/W	100%~200%	word

	698	Start time	R/W	0.1~600.0s	
	699	Over power alarm threshold	R/W	100~700%	
	700	Over power trip threshold	R/W	100~700%	word
	701	Over power trip delay	R/W	0.1~600.0s	
	702	Under power alarm threshold	R/W	0~100%	
	703	Under power trip threshold	R/W	0~100%	word
	704	Under power trip delay	R/W	0.1~600.0s	
	705	Phase sequence trip delay	R/W	0.1~600.0s	
	706	Short-circuit alarm threshold when starting	R/W	400%~800%	
	707	Short-circuit trip threshold when starting	R/W	400%~800%	word
	708	Short-circuit alarm threshold when running	R/W	400%~800%	
	709	Short-circuit trip threshold when running	R/W	400%~800%	
	710	Short-circuit trip delay	R/W	0.1~600.0s	word
	711	Fixed time limit overload alarm threshold	R/W	100-800%	word
	712	Fixed time limit overload trip threshold	R/W	100-800%	
	713	Fixed time limit overload trip delay	R/W	0.1~600.0s	word
	714	Voltage unbalance alarm threshold	R/W	10~99%	
	715	Voltage unbalance trip threshold	R/W	10~99%	
	716	Voltage unbalance trip delay	R/W	0.1~600.0s	
	717	overflow protection threshold	R/W	400%~800%	
Other alarm	718	Start times alarm threshold	R/W	1-10 unit :time	
	719	Start times protection delay	R/W	10-300min	
	720	Running time alarm threshold	R/W	1000-60000 unit:hour	
	721	Fault times alarm threshold	R/W	20-10000 unit:time	
	722-799	Retain	R		
High speed protection	800	High speed trip	R/W	Content is consistent with low	

	allowed/forbidden 1		speed,but the default value is different	
801	High speed trip allowed/forbidden 2	R/W		
802	High speed alarm allowed/forbidden 1	R/W		
803	High speed alarm allowed/forbidden 2	R/W		
804	High speed rated current	R/W		
805	High speed rated power	R/W		
806		R/W		
807	High speed trip level	R/W		
808	High speed tE trip level	R/W		
809	High speed inverse time protection start setting	R/W		
810	High speed inverse time protection set method	R/W		
811	High speed inverse time protection cooling time	R/W		
812	High speed inverse time protection alarm threshold	R/W		
813	High speed starting screen time	R/W		
814	High speed underload alarm threshold	R/W		
815	High speed underload trip threshold	R/W		
816	High speed underload trip delay	R/W		
817	High speed locked-rotor alarm threshold	R/W		
818	High speed locked-rotor trip threshold	R/W		
819	High speed locked-rotor trip delay	R/W		
820	High speed blocking alarm threshold	R/W		
821	High speed blocking trip threshold	R/W		
822	High speed blocking trip delay	R/W		

	823	High speed current unbalance alarm threshold	R/W		
	824	High speed current unbalance trip threshold	R/W		
	825	High speed current unbalance trip delay	R/W		
	826	High speed start timeout threshold	R/W		
	827	High speed start timeout time	R/W		
	828	High speed over power alarm threshold	R/W		
	829	High speed over power trip threshold	R/W		
	830	High speed over power trip delay	R/W		
	831	High speed under power alarm threshold	R/W		
	832	High speed under power trip threshold	R/W		
	833	High speed under power trip delay	R/W		
	834	High speed short-circuit alarm threshold when starting	R/W		
	835	High speed short-circuit trip threshold when starting	R/W		
	836	High speed short-circuit alarm threshold when running	R/W		
	837	High speed short-circuit trip threshold when running	R/W		
	838	Short-circuit trip delay	R/W		
	839	High speed fixed time limit overload alarm threshold	R/W		
	840	High speed fixed time limit overload trip threshold	R/W		
	841	High speed fixed time limit overload trip delay	R/W		
	842	High speed phase loss trip delay	R/W		
	843-899	Retain	R		
Start control	900	Self-start mode	R/W	0-start, 1-restore	word

	901	Self-start delay	R/W	0.1~60.0s	word
	902	Self-start control	R/W	0-Off、1-ON	word
	903	Control access	R/W	0-Panel; 1-Native; 2-Comm; 3-Remote; 4-1 in 3; 5- 1 in 2; 6-all control	word
	904	1 in 3 permission output1	R/W	0- Comm; 1- Native; 2- Panel; 3-Stop; 4-Remote the default is 0	word
	905	1 in 3 permission output2	R/W	0- Comm; 1- Native; 2- Panel; 3-Stop; 4-Remote the default is 1	word
	906	1 in 3 permission output3	R/W	0- Comm; 1- Native; 2- Panel; 3-Stop; 4-Remote the default is 2	word
	907	1 in 3 permission output4	R/W	0- Comm; 1- Native; 2- Panel; 3-Stop; 4-Remote the default is 3	word
	908	Start method	R/W	0-Protection mode,1-manual mode,2-two-step mode, 3-two-speed mode, 4-star triangle, 5-auto-step-down	word
	909	Start1 delay	R/W	0.1~60.0s	word
	910	Recovery voltage	R/W	70~95%	word
	911	Immediate restart time	R/W	0.1~10.0s	word
	912	Restart delay	R/W	1.0~60.0s	word
	913	Restart control	R/W	0=Off, 1=operates on start 1, 2= operates on start 2	word
	914	Sway electric time	R/W	0.5~300.0s	word
	915	Voltage drop		50-90% ≤Recovery voltage	
	916-949	Retain	R		word
Programmable setting	950	DO initial state setting	R/W	0-Normally on, 1- Normally off; bit0-bit4 correspond DO1-DO5	word
	951	DO1 Definition	R/W	0-No input, 1-start 1, 2-start 2, 3-start 3, 4-parking, 5-starting jumped contactor, 6-circuit breakers, 7-fault Alarm output, 8-tripping fault output,9-the output state stopped, 10-the starting state output, 11-the output operation state, 12-the communication control	

				output,13-the output device self-checking, 14-the device output power, 15-nowhere electric process output chain, 16-electric reset signal output, 17-protected mode have nowhere electricity output 1, 18-protected mode electricity output 2,19- logic diagram output 1 output logic diagram,20- logic diagram output 2, 21- logic diagram output 3, 22-30 corresponding DI1-19 control the DO output	
952	DO1 action setting(time)	R/W	0-Level; (3-250)-pulse time, unit:0.1S	word	
953	DO1 trip setting1	R/W	As same as 650	word	
954	DO1 trip setting2	R/W	As same as 651	word	
955	DO1 alarm setting1	R/W	As same as 651	word	
956	DO1 alarm setting2	R/W	As same as 651	word	
957	DO2 Programmable	R/W	As same as DO1(951-956)	word	
958	DO2 action setting(time)	R/W		word	
959	DO2 trip setting1	R/W		word	
960	DO2 trip setting2	R/W		word	
961	DO2 alarm setting1	R/W		word	
962	DO2 alarm setting2	R/W		word	
963	DO3 Programmable	R/W	As same as DO1(951-956)	word	
964	DO3 action setting(time)	R/W		word	
965	DO3 trip setting1	R/W		word	
966	DO3 trip setting2	R/W		word	
967	DO3 alarm setting1	R/W		word	
968	DO3 alarm setting2	R/W		word	
969	DO4 Programmable	R/W	As same as DO1(951-956)	word	
970	DO4 action setting(time)	R/W		word	
971	DO4 trip setting1	R/W		word	
972	DO4 trip setting2	R/W		word	
973	DO4 alarm setting1	R/W		word	
974	DO4 alarm setting2	R/W		word	
975	DO5 Programmable	R/W	As same as DO1(951-956)	word	
976	DO5 action setting(time)	R/W		word	

	977	DO5 trip setting1	R/W		word
	978	DO5 trip setting2	R/W		word
	979	DO5 alarm setting1	R/W		word
	980	DO5 alarm setting2	R/W		word
	981-986	Retain	R		
	987	DI type	R/W	Bit0-Bit8 correspond DI1-9, 0-Normally on; 1- Normally off	
	988	DI1 programmable setting	R/W	1-Ordinary DI, 2-starting 1(in situ), 3-starting 1(remote), 4-starting 2(in situ), 5-starting 2(remote), 6-parking (in situ), 7-parking (remote), 8-reset, 9-emergency stop, 10-external fault, 11-single point 1 (in situ) start-stop, 12-single point 1 (remote) start-stop, 13-single point 2 (in situ) start-stop, 14-single point 2 (remote) start-stop, 15-single point 1 start/stop, 16-single point 2 start/stop, 17-control over 1, 18-control over 2	word
	989	DI2 programmable setting	R/W	ditto	word
	990	DI3 programmable setting	R/W		word
	991	DI4 programmable setting	R/W		word
	992	DI5 programmable setting	R/W		word
	993	DI6 programmable setting	R/W		word
	994	DI7 programmable setting	R/W		word
	995	DI8 programmable setting	R/W		word
	996	DI9 programmable setting	R/W		word
	997-1002	Retain	R		
	1003	Logic diagram1	R/W	0-off;1-A;2-A*B;3-A+B;4-A*	word

				$B * C$;5- $(A + B) * C$;6- $(A * B) + C$; 7- $A + B + C$;8- $A * B * C * D$;9- $(A + B) * C * D$;10- $(A * B + C) * D$;11- $(A + B + C) * D$;12- $A * B * C + D$;13- $(A + B) * C + D$;14- $A * B + C + D$;15- $-A + B + C + D$;16- $A * B * C * D * E$; 17- $(A + B) * C * D * E$;18- $(A * B + C) * D * E$;19- $(A + B + C) * D * E$;20- $(A * B * C + D) * E$;21- $((A + B) * C + D) * E$;22- $(A * B + C + D) * E$;23- $(A + B + C + D) * E$;24- $A * B * C * D + E$;25- $(A + B) * C * D + E$;26- $(A * B + C) * D + E$;27- $(A + B + C) * D + E$;28- $A * B * C + D + E$;29- $(A + B) * C + D + E$;30- $A * B + C + D + E$;31- $-A + B + C + D + E$	
1004	Input A	R/W	Low-byte:0-Close;1-9 correspond to DI1-19;17-21 correspond to DO1 - DO6;27-Starting 1;28-Starting 2;29-Starting 3;30-Stop,31-Emergency shutdown;32-Stop state;33-Starting state;34-Running state;35-Alarm status;36-Trip status;49-80 correspond to trip type;81-112 correspond to alarm types High byte:0-Logical,1-illogical	word	
1005	Input B	R/W	As same as 1004	word	
1006	Input C	R/W		word	
1007	Input D	R/W		word	
1008	Input E	R/W		word	
1009	Input A relay	R/W	0.0-60.0s	word	
1010	Input B relay	R/W	0.0-60.0s	word	
1011	Input C relay	R/W	0.0-60.0s	word	
1012	Input D relay	R/W	0.0-60.0s	word	
1013	Input E relay	R/W	0.0-60.0s	word	
1014	Logic diagram 2	R/W	As same as logic diagram 1 (address:1003~1013)	word	
1015	Input A	R/W		word	
1016	Input B	R/W		word	

	1017	Input C	R/W		word
	1018	Input D	R/W		word
	1019	Input E	R/W		word
	1020	Input A relay	R/W		word
	1021	Input B relay	R/W		word
	1022	Input C relay	R/W		word
	1023	Input D relay	R/W		word
	1024	Input E relay	R/W		word
	1025	Logic diagram 2	R/W	As same as logic diagram 1 (address:1003~1013)	word
	1026	Input A	R/W		word
	1027	Input B	R/W		word
	1028	Input C	R/W		word
	1029	Input D	R/W		word
	1030	Input E	R/W		word
	1031	Input A relay	R/W		word
	1032	Input B relay	R/W		word
	1033	Input C relay	R/W		word
	1034	Input D relay	R/W		word
	1035	Input E relay	R/W	word	
	1036-1039	Retain	R		word
Communication setting	1040	ADD 1	R/W	1~247	word
	1041	Baud rate1	R/W	0-38400,1-19200,2-9600,3-4800,4-2400,5-1200	word
	1042	Check digit 1	R/W	0-No check, 1-2stop bit, 3-Odd, 4-Even	word
	1043	ADD 2		1~247	word
	1044	Baud rate2	R/W	0-38400,1-19200,2-9600,3-4800,4-2400,5-1200,6-Profibus	word
	1045	Check digit 2	R/W	0-No check, 1-2stop bit, 3-Odd, 4-Even	word
	1047-1099	Retain	R/W		
DI displacement record 1	1100	DI NO.	R	1-9 correspond to DI1-9	
	1101	DI status	R	0-open 1-closed	
	1102	Action 1time-year month	R	High byte:year,low byte:month	
	1103	Action 1time-day hour	R	High byte:day,low byte:hour	
	1104	Action 1time-minute second	R	High byte:minute,low byte:second	
	1105-	Retain	R		

	1107				
DI displacement record 2-8	1108- 1115	Ditto	R	Ditto	
	1116- 1123		R		
	1124- 1131		R		
	1132- 1139		R		
	1140- 1147		R		
	1148- 1155		R		
	1156- 1163		R		
	1164- 1259	Retain	R		
Start record 1	1300	Start position	R	0-External start 1-Comm 2-Native 3-Panel 4-Remote 5-Self-start 6-Restart	
	1301	Maximum current when starting	R	Unit:1%	
	1302	Minimum voltage when starting	R	Unit:1%	
	1303	Result of starting	R	1-stop when starting 2-go into running status 3-go into trip status	
	1304	Action 1time-year month	R	High byte:year,low byte:month	
	1305	Action 1time-day hour	R	High byte:day,low byte:hour	
	1306	Action 1time-minute second	R	High byte:minute,low byte:second	
	1307	Starting time	R	Unit:0.1S	
Start record 2-8	1308- 1315	ditto	R	ditto	
	1316- 1323		R		
	1324- 1331		R		
	1332- 1339		R		
	1340- 1347		R		

	1348-1355		R		
	1356-1363		R		
	1364-1499	Retain	R		
Stop record 1	1500	Stop position	R	0-External stop 1-Comm 2-Native 3-Panel 4-Remote 5-Emergency stop 6-Voltage loss stop	
	1501	Action 1time-year month	R	High byte:year,low byte:month	
	1502	Action 1time-day hour	R	High byte:day,low byte:hour	
	1503	Action 1time-minute second	R	High byte:minute,low byte:second	
	1504-1507	Retain	R		
Stop record 2-8	1508-1515	ditto	R	ditto	
	1516-1523		R		
	1524-1531		R		
	1532-1539		R		
	1540-1547		R		
	1548-1555		R		
	1556-1563		R		
	1564-1699	Retain	R		
Restart record 1	1700	Cause of voltage shock	R	0-All three phase lost power 1-A phase 2-B phase 3-C phase	
	1701	Minimum voltage	R	Unit :1%	
	1702	Time of voltage shock		Unit :0.1S	
	1703	Action after voltage shock		1-keep 2-restart 1 3-restart 2	
	1704	Action 1time-year month	R	High byte:year,low byte:month	
	1705	Action 1time-day hour	R	High byte:day,low byte:hour	

	1706	Action 1time-minute second	R	High byte:minute,low byte:second	
	1707	Retain	R		
Restart record2-8	1708- 1715	ditto	R	ditto	
	1716- 1723		R		
	1724- 1731		R		
	1732- 1739		R		
	1740- 1747		R		
	1748- 1755		R		
	1756- 1763		R		
	1804- 1899	Retain	R		
Parameter change record 1	1900	Change time-year month	R		
	1901	Change time-day hour	R		
	1902	Change time-minute second	R		
	1903	First data	R		
	1904	Length of comm data	R		
	1905	Set position	R	0=lcd,1=rs485-1,2=rs485-2,	
Parameter change record 2-8	1906- 1911	ditto	R	ditto	
	1912- 1917		R		
	1918- 1923		R		
	1924- 1929		R		
	1930- 1935		R		
	1936- 1941		R		
	1942- 1947		R		
	1948- 2019	Retain	R		

Power on record1	2020	Power on index	R	Record the number of this time power on	
	2021	Power on time-year month	R		
	2022	Power on time-day hour	R		
	2023	Power on time-minute second	R		
Power on record2-8	2024-2027	ditto		ditto	
	2028-2031				
	2032-2035				
	2036-2039				
	2040-2043				
	2044-2047				
	2048-2051				
Power off 1	2052	Power off index	R	Record the number of this time power off	
	2053	Power off time-year month	R		
	2054	Power off time-day hour	R		
	2055	Power off time-minute second	R		
Power off 2-8	2056-2059	ditto		ditto	
	2060-2063				
	2064-2067				
	2068-2071				
	2072-2075				
	2076-2079				
	2080-2083				

	2084-2089	Retain	R		
	2090-2095	ditto	R		
Fault record 1	2100	Trip status 1	R		
	2101	Trip status 2	R		
	2102	Alarm status 1	R		
	2103	Alarm status 2	R		
	2104	Action 1 time-year month	R		
	2105	Action 1 time-day hour	R		
	2106	Action 1 time-minute second	R		
	2107	Fundamental wave switch, sensor type	R	bit0: fundamental wave switch; bit1: PTC/NTC type	
	2108	A phase current	R		
	2109	B phase current	R		
	4010	C phase current	R		
	2111	A phase voltage	R		
	2112	B phase voltage	R		
	2113	C phase voltage	R		
	2114	Total apparent power	R		
	2115		R		
	2116	Total active power	R		
	2117		R		
	2118	Total reactive power	R		
	2119		R		
	2120	Total power factor	R		
	2121	Frequency	R		
	2122	Zero sequence current	R		
	2123	Zero sequence voltage	R		
	2124	PTC/NTC resistance	R		
	2125	Leakage current	R		
2126	DI status	R			
2127	DO status	R			
2128	Motor status	R	Bit1 stop; Bit2 start; Bit3 run; Bit4 alarm		
2129-2149	Retain	R			
Fault record 2-8	2150-2199	ditto	R	ditto	

	2200-2249		R		
	2250-2299		R		
	2300-2349		R		
	2350-2399		R		
	2400-2449		R		
	2450-2499		R		
	2500-4999	Retain	R		
Customize mailing address	5000	Correspond value of custom address 1	R	As same as the corresponding mailing address	
	5001	Correspond value of custom address 2	R		
	~	~	R		
	5119	Correspond value of custom address 120	R		
	5120-5299	Retain	R		
	5300	Correspond address of custom address 1	R/W		
	~	~	R/W		
	5419	Correspond address of custom address 120	R/W		

9 Features and Functions

9.1 Permissions programmable

Protector has perfect control authority programmable function, with permission for "1 in 2" or "1 in 3" use.

When the control permission is "1 in 2", the user can define the control permission output 1 and output 2: either of the panel, communication, remote and native (both definitions are not repeatable).

For example, control permissions are defined as "1 in 2", control permission output type output 1 is defined as "communication control", output 2 is defined as "panel control". The DI6 is defined as (control permission 1). When DI6(control permission 1) is disconnected, the control mode corresponding to the control permission output 1 takes effect, and the control mode corresponding to the output 2 takes effect when the DI6(control permission 1) is connected. The control permissions are selected as shown in Table 13 below:

Table 13

Control Permission Type	DI6 Control Permission Input 1 State
Communication control	0

Panel control	1
---------------	---

When the control permissions are set to “1 in 3”, The user can define control rights output 1, output 2, output 3, and output 4 as either of the panel, communication, remote, and native, stop (each output definition is not repeatable), The effective output is selected by DI6(control permission 1), DI7(control permission 2) on-off. If control permission output 1 is defined as communication control, Output 2 is defined as panel control, Output 3 is defined as native control, Output 4 is defined as remote control, The control permissions are selected as shown in Table 14 below:

Table 14

Control permissions	DI Input state	
	DI7 Control permission 1	DI8 Control permission 2
Communication control	0	0
Panel control	0	1
Native control	1	0
Remote control	1	1

Note : "0" means switch input disconnected , "1" means turn on

9.2 Logic programmable

The protector has perfect logic programmable function, and the user can program and define according to the required logic output function. Each logic function consists of five programmable input conditions A、B、C、D、E, freely combined by "with "," or" relations. The programmable content of each input condition and the combination of input conditions can be seen in Table 11 menu.

Suppose the user needs to output passive signal when any fault occurs in blocking, short circuit, time limit overload, phase break, current imbalance, can set DO3(or other DO) to logic diagram output 1, set the condition of logic output 1 to $A*B*C*D*E$, and set the condition input A、B、C、D、E to block, short circuit, time limit overload, phase break, current imbalance fault, then block, short circuit, time limit overload, phase break, current imbalance fault any fault occurs, DO3—— logic diagram output 1 action, output passive signal.

Note : "+" representation and logic , " * " representation or logic.

9.3 Custom communication address

The protector has the function of customizing communication address, which makes communication reading more convenient and effective.

There are 120 communication addresses for user customization. Address 5000-5119 and 5300-5419, the corresponding data values can be customized. If the value of 5300 is written as 2010, the address 5000 is the same as the address 2010 data.

Example: Suppose the user needs to read and write the original address 2003,2300,2307,2309,2335,2357,2758,2800 frequently. These addresses are not continuous addresses, each read an address data, need to send a MODBUS read command.

In this case, the efficiency can be improved by customizing the address function: the user can write the address 5300-5307 as 2003,2300,2307,2309,2335,2357,2758,2800 respectively, so that the definition of the address 5000-5007, read and write, value range and so on will correspond to the above address one by one. At this time, the user only needs to send a read command to achieve all data read and write.

10 Examples of ordering

Example1: specific model: ARD2M-100/CP

Technical requirements: motor power37KW

Communication protocol:MODBUS RTU protocol; PROFIBUS protocol

Auxiliary power:AC 220V

Example2: specific model: ARD2M-100/CC

Technical requirements: motor power37KW

Communication protocol:2 channels MODBUS RTU protocol

Auxiliary power:AC 220V